

1st Reading 11/24/97

ORDINANCE NO. 97-179
BY: Kenneth J. Kovach

Accepting an agreement relative to the establishment of the Ohio Telecommunications Network Council.

WHEREAS, the City of Shaker Heights is one of several municipalities considering the establishment of a Council of Governments ("COG") for the purpose of undertaking a joint program for the creation and operation of a fiber optics telecommunications system serving the member municipal corporations; and

WHEREAS, in order for the City to: (1) participate in the creation of COG bylaws and Board of Directors; (2) proceed with and evaluate a Feasibility Study; (3) participate in third party validation of the Feasibility Study; and (4) participate in Phase I network construction, it is necessary to enter into an agreement establishing the COG, to be called the Ohio Telecommunications Network Council ("OTN"); and

WHEREAS, this Council has been fully informed of the potential financial benefits to the City were the OTN to prove successful, as well as the financial risks were the OTN to prove unsuccessful, as described in the memorandum from the City Manager of the City of Bedford, Ohio, dated October 7, 1997, attached hereto and included herein by reference as Exhibit 1; and

WHEREAS, this Council has also been expressly advised of the "up-front" costs which may be required from the City subsequent to its entering into an agreement for the establishment of OTN, as set forth in Exhibit 1; and

WHEREAS, the Mayor and the Chief Administrative Officer have recommended approval of the OTN agreement (Exhibit 2); and

WHEREAS, this Council finds that the establishment of the OTN, as set forth in said agreement, is in the best interests of the residents of the City, and will serve to enhance and improve the public health, safety, peace and general welfare.

NOW, THEREFORE, BE IT ORDAINED by the Council of the City of Shaker Heights, State of Ohio:

Section 1. This Council hereby authorizes the Mayor and Director of Finance to enter into an agreement for the establishment of a Council of Governments, to be called the Ohio Telecommunications Network Council, including the adoption of bylaws therefor, for the purpose of undertaking a joint program for the creation and operation of a fiber optics telecommunications system serving the member municipal corporations. Said agreement and bylaws shall be in substantially the form as attached hereto and incorporated herein by reference as Exhibit 2, as approved by the Director of Law.

Section 2. The City shall be represented in the OTN Council by the Chief Administrative Officer.

Section 3. The Chief Administrative Officer, as the City's representative in the OTN Council, is authorized and directed to approve the bylaws governing the Ohio Telecommunications Network Council in substantially the form as attached hereto and included herein by reference and as approved by the Director of Law, and with such changes, if any, as may be determined by the Chief Administrative Officer to be necessary or desirable and not adverse to the interests of the City, such determination to be conclusively evidenced by the Chief Administrative Officer's affirmative vote for the adoption of the bylaws.

Section 4. The OTN Council is authorized and requested to take the actions on behalf of the City set forth in the Council Agreement and Bylaws.

Section 5. This ordinance shall take effect from and after the earliest time allowed by law.

Enacted _____, 1997.

Approved this _____ day of _____, 1997.

PATRICIA S. MEARNs, Mayor

Attest:

WILLIAM J. SCHUCHART
Clerk of Council

coun97\tlb1111a

OTN MEMORANDUM

Date: October 7, 1997

To: William J. Schuchart
Chief Administrative Officer
City of Shaker Heights Via Fax

From: Vilas Gamble, City Manager; Bedford, Ohio
Skip Dodson, Project Consultant

Copy to: Bob Jennings, Public Facilities Investment Corp. (PFIC)
Hans Boli, Northern Telecom (Nortel)
Ivan Otto, Esq., Squire Sanders and Dempsey, LLP (SS&D)
David Lu, Esq., Squire Sanders and Dempsey, LLP

Subject: Ohio Telecommunications Network (OTN)

You have asked us to clarify several OTN project issues. We have reviewed your questions with SS&D, PFIC, and Nortel and respond as follows:

1. Financial risks to the municipality break down into two categories:
 - a) Up front costs are expected to be approximately \$1.00 to \$1.50 per capita to pay the cost of third party Feasibility Study validation and Council of Governments (COG) organizational expenses such as printing, postage, meeting minutes, etc.. If the project proceeds, these costs will be reimbursed out of the funds received from the non-recourse financing. In the event the project does not proceed, they are lost. In the case of Shaker Heights this would be about \$32,000 to \$48,000.
 - b) Project Failure — In the event the project fails, the municipality may incur additional interest expense when it borrows money for other purposes, but it is difficult to determine how much this might be. The risk to the municipality is the same as the risk the municipality incurs in participating in other non-recourse revenue bond issues such as water and sewer bond issues.
2. Fiscal officers certificate — The Agreement for Establishment of Ohio Telecommunications Network Council (COG Agreement) includes a fiscal officer's certificate in order to comply with statutory requirements. As a practical matter, the municipalities are not being asked to make any financial commitment at the time the COG is formed. The COG is being formed to establish a formal entity to:
 - a) Enter into a contract with Public Facilities Investment Corporation (PFIC) so that the feasibility study can be received and reviewed;
 - b) Establish a formal work group and process to evaluate the feasibility study and recommend to the member municipalities that the project proceed to the feasibility validation stage. This work group will be the COG Assembly, consisting of one representative from each municipality, and the COG Board of Directors.

If the COG Assembly determines that the project should proceed to the feasibility validation stage, the member municipalities will be asked to provide the necessary funds at that time for a third party validation of the Feasibility Study to satisfy lending requirements.

As mentioned above, it is anticipated that the funds required will be \$1.00 to \$1.50 per capita for each municipality. We expect to be able to proceed with the project with a minimum population base of approximately 80,000 people which equates to approximately 50,000 telephone lines. In other words, the COG can be formed with a minimum of four or five of the larger communities that executed letters of intent. Joining the COG does not commit the municipality to providing any funds, however only those municipalities that fund the validation study will be included in the first phase of the network development. It will be helpful and save time if Shaker Heights appropriates the funds for the validation study when it joins the COG, but it is not essential. Those funds can be appropriated at the time the decision is made to proceed with the validation study. The funds will be needed sometime in December, 1997 or early January, 1998.

3. Technological obsolescence — The feasibility study allows for technological obsolescence factors and amortizes the initial project cost over ten years. This is well within the foreseeable life span of the network design which will be at least fifteen (15) to twenty years (20). The Feasibility Study also provides for appropriate expenditures to maintain and upgrade the network as new technology becomes available. For example, it is anticipated that OTN will serve providers of wireless telecommunication services after appropriate due diligence and negotiation with wireless service providers.

It is anticipated that fiber optic technology will continue to be used well into the 21st Century. Various forms of wireless telecommunication networks and technology will be developed along with fiber optic networks, but wireless technology does not make fiber optic technology obsolete. In general, wireless technology will serve mobile telecommunication needs and areas where it is too expensive to deploy fiber optic networks such as areas with low population density and difficult terrain for the distribution and service drop of unbundled services.

The anticipated revenue bond or lease financing is premised on a ten (10) year issue to address the potential of technological advances impacting fiber optic technology.

4. Non-recourse debt — Each participating municipality will issue non-recourse debt to finance its portion of the project. The municipality will not be required to guarantee any portion of the debt. The COG will handle all of the administrative issues related to this debt, but the debt instruments will be issued by each member municipality. Squire, Sanders & Dempsey advises us that this debt will not affect the municipality's debt limit.

5. Commitment to COG — Joining the COG does not commit Shaker Heights to proceeding with the OTN project. Joining the COG gives Shaker Heights the opportunity to:
- a) Establish the COG By-laws and Board of Directors,
 - b) Have the Feasibility Study evaluated,
 - c) Participate in third party validation of the Feasibility Study (requires commitment of funds),
 - d) Participate in Phase I network construction.

You may note that there are a number of inconsistencies between this memo and the COG Agreement that was distributed. David Lu of SS&D is revising the COG Agreement so that it is consistent with the provisions of this memo and will forward the revised agreement under separate cover so that you have it no later than Thursday, October 9, 1997.

Bedford placed an ordinance to join the COG on first reading last night, Monday, October, 6, 1997 with a 6-1 vote. Vilas will forward a copy of the ordinance under separate cover.

Please give us a call if you need additional information.

AGREEMENT AND BYLAWS
OF THE
OHIO TELECOMMUNICATIONS NETWORK COUNCIL

TABLE OF SECTIONS

Agreement for Establishment
of the Ohio Telecommunications Network Council

<u>Section</u>	<u>Page</u>
Recitals	1
Section 1. Name	1
Section 2. Fiscal Year	1
Section 3. Representation of Members	1
Section 4. Adoption of Bylaws	2
Section 5. Programs of the Council	2
Section 6. Withdrawal of a Member	3
Section 7. Inclusion of Additional Members	3
Section 8. Amendments	3
Section 9. Term	3
Section 10. Termination	3
Section 11. Effectiveness and Counterparts	4

Signatures

Fiscal Certificates

Exhibit A - Bylaws Governing the Ohio Telecommunications Network Council

AGREEMENT
FOR ESTABLISHMENT OF
OHIO TELECOMMUNICATIONS NETWORK COUNCIL

This Agreement for Establishment of Ohio Telecommunications Network Council (the "Agreement") is made and entered into as of _____, 199__ by and between the municipal corporations identified below that are to be the members of the Ohio Telecommunications Network Council (the "Council"):

Recitals

WHEREAS, Revised Code Chapter 167 provides, in general, that the governing bodies of any two or more political subdivisions may enter into an agreement establishing a regional council of governments for the purposes of promoting cooperative arrangements and agreements among its members and between its members and government agencies or private persons or entities, performing functions and duties which its members can perform and addressing problems of mutual concern; and

WHEREAS, the municipal councils of _____ (the founding members) seek to establish the Ohio Telecommunications Network Council for the purpose of undertaking a joint program for the establishment and operation of a fiber optics telecommunications system serving the member municipal corporations; and

WHEREAS, each of the founding members has enacted or intends to enact an ordinance that authorizes its participation in the Council and the execution of this Agreement on its behalf.

Agreement

NOW, THEREFORE, in consideration of the services to be made available by the Council, it is agreed by and between the undersigned founding members of the Council and any additional municipal corporations that may hereafter become members of the Council (collectively the "Members"):

Section 1. Name. The name of the group composed of all Members shall be the "Ohio Telecommunications Network Council".

Section 2. Fiscal Year. The fiscal year of the Council shall be the twelve-month period beginning January 1 and ending December 31 (the "Fiscal Year"). In the event that the fiscal year for Ohio municipal corporations should be changed to a period other than the twelve-month period beginning January 1 and ending December 31, the Fiscal Year of the Council may be changed to conform to such change upon the approval of the Board of Directors of the Council.

Section 3. Representation of Members. The representative of each Member shall be the executive officer of that Member. The representatives of all the Members shall collectively constitute the Assembly of the Council.

Section 4. Adoption of Bylaws. Within 45 days following approval and execution of this Agreement by those founding Members (identified in the Recitals of this Agreement) whose populations shall total at least 70,000 people, the representatives to the Council of those founding Members who have approved and executed this Agreement shall meet for the purpose of adopting bylaws pursuant to Revised Code Section 167.04 (the "Bylaws"). The affirmative vote of at least a majority of all representatives of those founding Members who have approved and executed this Agreement shall be required for the adoption of the Bylaws. The Bylaws shall include but not be limited to provisions that:

- (A) establish a governing board of the Council which shall be called the Board of Directors;
- (B) designate the officers of the Council and the method of selection thereof;
- (C) provide a method for the appointment of advisory committees for the programs of the Council;
- (D) appoint a fiscal officer for the Council and its programs who shall be called the Treasurer; and
- (E) regulate the conduct of the Council's business.

Section 5. Programs of the Council. The Council shall establish a cooperative program to plan, finance, construct, equip, operate and maintain a regional fiber optics telecommunications network (the "Network") to serve the Member municipal corporations. The Council may establish such additional cooperative programs as the Board of Directors may approve. Each program, including the Network, shall be established by a written program agreement between the Council and the Members of the Council whose governing bodies have determined to participate in the program and have approved the program agreement. Each program agreement shall be reviewed and approved by the Board of Directors prior to execution by any Member.

Each program agreement shall include, but not be limited to, provisions that:

- (A) direct the Board of Directors concerning the management of the program and define matters which must be submitted for decision to the Members participating in that program;
- (B) establish procedures for budgeting program costs and surplus revenues and apportioning program costs and surplus revenues among the participating Members;
- (C) establish one or more funds into which all contributions of money for program costs shall be deposited;

(D) determine the method for including additional Members in the program or permitting other organizations to contract with the Council for services under a program, if determined to be necessary or desirable;

(E) determine the duties of the Treasurer with respect to the fiscal management of the program; and

(F) determine the disposition, upon termination of the program, of any supplies, equipment, facilities or moneys held in connection with the operation of the program.

Section 6. Withdrawal of a Member. Prior to the execution of any program agreement, including the program agreement for the Network, any Member of the Council may withdraw from the Council for any reason upon giving 60 days' notice, but such withdrawing Member shall not receive any refund of costs paid for validation of the feasibility study for the Network.

After execution of any program agreement, including the program agreement for the Network, any Member wishing to withdraw from participation in the Council shall notify the Board of Directors of the Council on or before _____ preceding the first day of the Fiscal Year in which the Member will withdraw. That notification must include a certified copy of a duly enacted ordinance of the governing body of that Member determining that the Member shall withdraw and the effective date of withdrawal, which must be the first day of a Fiscal Year. A Member which has withdrawn from the Council shall be deemed to have withdrawn from the System and all other Council programs in which it was a participating Member. Each program agreement shall govern the disposition of any contributions by the withdrawing Member to each program of the Council in excess of that Member's share of the costs of that program as determined by the program agreement. The Board of Directors shall determine whether the withdrawing Member has contributed any other moneys or facilities for the operation of the Council in excess of that Member's share of those costs not attributable to any specific program of the Council, and, if so, the Board of Directors may provide for the return to that Member of any such excess. After withdrawal, the withdrawing entity may not become a Member again until it has fully complied with the procedures contained in Section 7 hereof.

Section 7. Inclusion of Additional Members. Any municipal corporation in the State of Ohio may apply to become a Member of the Council by submitting an application in writing to the Board of Directors, accompanied by a duly enacted ordinance of its governing body requesting inclusion in the Council. The Board of Directors shall review the application and make a recommendation to the Assembly concerning the inclusion of the applicant in the Council. The applicant shall be included in the Council and deemed a Member hereunder if its inclusion is approved by the affirmative vote of at least a majority of the representatives in the Assembly and the applicant thereafter executes the Agreement, approves the Bylaws and appropriates and remits to the Treasurer an initial monetary assessment for costs of the Council in an amount approved by the Assembly. The applicant shall thereafter be a Member and be assessed its portion of the Council's costs by the same method and using the same formula as for any other Member, in accordance with the Bylaws.

Section 8. Amendments. This Agreement may be modified, amended or supplemented in any respect not prohibited by law upon the approval of the modification, amendment or supplement by the governing bodies of at least a majority of the Members and the amendment, modification or supplement shall thereupon become binding upon all Members.

Section 9. Term. It is the express intention of the Members that this Agreement shall continue for an indefinite term, but may be terminated as herein provided.

Section 10. Termination. In the event that the governing bodies of two-thirds of the Members, by duly enacted ordinances, determine that this Agreement shall be terminated, the Board of Directors shall meet within 30 days following its receipt of certified copies of those ordinances. At that meeting the Board of Directors shall determine the date upon which this Agreement and the activities and operations of the Council shall terminate and shall make recommendations to the Assembly with respect to any matters that must be resolved in connection with the termination of the Council and that is not addressed by this Agreement, the Bylaws or any program agreement.

Upon termination of this Agreement, each program and program agreement of the Council, including the System and the System Agreement, shall terminate, unless [the governing bodies of two-thirds of the Members][and the Board of Directors] determine that a program shall continue and make provision for its continued operation without the Council. After payment of all known obligations of the Council in connection with each terminated program, any surplus remaining in any funds of any terminated programs shall be distributed among the Members participating in the respective programs in the manner provided in the program agreements. After payment of all known obligations of the Council, other than those incurred in connection with any program, any surplus remaining in any funds of the Council other than program funds shall be distributed among the Members in the manner recommended by the Board of Directors and approved by the affirmative vote of a majority of the representatives in the Assembly.

No Member shall be required, by or under this Agreement or the Bylaws, by an amendment or otherwise, to pay any sum upon termination hereof, unless it shall have expressly agreed thereto.

Section 11. Effectiveness and Counterparts. This Agreement shall not be effective until signed by the representatives of two-thirds of the founding Members as authorized by duly enacted ordinances of the governing bodies of each of those Members. This Agreement may be signed in separate counterparts on behalf of any one or more than one of the Members, without necessity for any one counterpart to be signed on behalf of all Members. Separately signed counterparts shall be filed with the Recording Secretary of the Council and shall constitute one Agreement.

IN WITNESS WHEREOF, the undersigned representatives and officers of the respective Members, pursuant to duly enacted ordinances, have on behalf of their respective Members signed this Agreement (in counterparts) on the respective dates indicated below opposite their respective signatures but effective as of _____, 1997.

THE CITY OF _____, OHIO

Date: _____

By: _____
Executive Officer

Date: _____

And By: _____
Director of Finance

Date: _____

And By: _____
Director of Law

FISCAL CERTIFICATE

The undersigned fiscal officer of _____, Ohio (the City), under the aforesaid Agreement for Establishment of the Ohio Telecommunications Network Council, certifies that the moneys required to meet the obligations of the City during the fiscal year ending December 31, 1997 under that Agreement have been lawfully appropriated by the Council of the City for those purposes and are in the treasury of the City or in the process of collection to the credit of an appropriate fund, free from any previous encumbrances. This Certificate is given in compliance with Sections 5705.41 and 5705.44 of the Revised Code.

Director of Finance
_____, Ohio

Dated: _____, 1997

EXHIBIT A
BYLAWS
GOVERNING
OHIO TELECOMMUNICATIONS NETWORK COUNCIL

TABLE OF SECTIONS

<u>Section</u>	<u>Title</u>	<u>Page</u>
Section 1.	Definitions	1
Section 2.	Assembly	1
	(A) Composition	1
	(B) Meetings	1
	(C) Resolutions	2
	(D) Powers and Duties of Assembly	2
Section 3.	Board of Directors and Officers	3
	(A) Composition of Board of Directors	3
	(B) Officers	3
	(C) Election Procedures	3
	(D) Vacancies	3
	(E) Duties of Officers	3
	(F) Meetings of Board of Directors	4
	(G) Powers and Duties	5
Section 4.	Treasurer	5
Section 5.	Administrator	5
Section 6.	Advisory Committees	6
Section 7.	Employees and Consultants	6
Section 8.	Equipment and Facilities	7
Section 9.	Council Funds	7
Section 10.	Estimate of Council Costs; Payments by Members	8
Section 11.	Conduct of Meetings	9
Section 12.	Amendments	9
Section 13.	Transition	9

BYLAWS
GOVERNING
OHIO TELECOMMUNICATIONS NETWORK COUNCIL

Recitals

WHEREAS, the Members of the Ohio Telecommunications Network Council (the "Council") have entered into the Agreement For Establishment of Ohio Telecommunications Network Council (the "Agreement") for the purpose of undertaking a joint program for the establishment and operation of a fiber optics telecommunications network (the "Network") serving its Members and such other programs entered into by the Council and participating Members;

WHEREAS, Revised Code Section 167.04 requires the Council to adopt bylaws designating the officers of the Council and the method of selection thereof, creating a governing board to act for the Council, appointing a fiscal officer, and providing for the conduct of the Council's business;

WHEREAS, the governing body of each Member has by duly enacted ordinance approved the Agreement and authorized its representative to approve these Bylaws, and the representatives of the Members have met for the purpose of adopting these Bylaws in accordance with Revised Code Section 167.04 and Section 4 of the Agreement;

Bylaws

NOW, THEREFORE, the following provisions shall constitute the Bylaws of the Ohio Telecommunications Network Council:

Section 1. Definitions. Any capitalized word or phrase used in these Bylaws and not otherwise defined herein, shall have the meaning given in the Agreement, as that Agreement may, from time to time, be amended, modified, or supplemented in accordance with Section 8 thereof.

Section 2. Assembly. The Assembly shall be the legislative body of the Council.

(A) Composition. The Assembly shall be composed of the representatives of the Members, who shall be the executive officers of the Members in accordance with Section 3 of the Agreement. All representatives to the Assembly (except as otherwise provided herein) shall serve without compensation. The person serving as Treasurer of the Council and the person who may be serving as Administrator of the Council (as provided in Sections 4 and 5 of these Bylaws) each shall be an ex-officio member of the Assembly and may attend all meetings of the Assembly but shall not count for purposes of determining a quorum and shall not have a vote.

(B) Meetings. The Assembly shall meet at least two times each year, on dates to be established by the Board of Directors, and the Assembly may hold such additional meetings as may be requested by the Chairman or as may be requested, in writing to the Recording Secretary, by any [three] or more representatives to the Assembly. Written notice of each meeting shall be served by the Recording Secretary upon each Assembly representative not less

than 24 hours preceding the time for meeting, and shall state the date, time and place of the meeting and subject or subjects to be considered at the meeting. The requirements of and procedures for notice may be waived in writing by each representative and any representative shall be deemed conclusively to have waived such notice with respect to a meeting by his or her attendance at that meeting.

Pursuant to Revised Code Section 121.22(F), the Assembly shall, by rule, establish a reasonable method whereby any person may determine the time, place and purpose of its meetings. All meetings of the Assembly shall be open to the public, subject to the exceptions in Revised Code Section 121.22(G). The Assembly may, but need not, adopt other rules.

The Chairman of the Council (and in the Chairman's absence the Vice-Chairman of the Council), elected by the Assembly pursuant to Section 3 of these Bylaws, shall preside at Assembly meetings. The Recording Secretary, elected by the Assembly pursuant to Section 3 of these Bylaws, shall keep a record of the Assembly's proceedings, including a journal of all minutes of all meetings of the Assembly. The Recording Secretary shall also be responsible for all official documents, resolutions and actions of the Assembly and shall distribute a copy of the minutes of each Assembly meeting to each Assembly member. If for any reason the office of Recording Secretary is vacant, the Chairman shall designate a member of the Assembly to serve as temporary Recording Secretary until a Recording Secretary is selected by the Assembly in accordance with Section 3 of these Bylaws.

(C) Resolutions. A majority of all representatives to the Assembly, including those represented by proxy, shall constitute a quorum to transact business except as otherwise provided in the Agreement or these Bylaws. Each representative (including the Chairman, Vice-Chairman and Recording Secretary) shall have one vote; provided, however, that when a matter is to be voted upon which is of concern to only one or more but not all programs of the Council, only representatives of Members participating in those programs shall be entitled to vote on that matter, a majority of only the Members participating in those programs shall constitute a quorum, including those represented by proxy, and only those representatives shall be counted for purposes of determining whether a quorum is present. All legislative action of the Assembly shall be by resolution entered on its records. Except as otherwise provided in the Agreement, the affirmative vote, of at least a majority including those represented by proxy, of all of the representatives to the Assembly eligible to vote on a matter (not counting vacancies) shall be required for the enactment of every resolution. Unless otherwise specifically stated in the resolution, all resolutions shall be effective immediately upon enactment, subject to any authorizations or certifications required by the Revised Code to be made by the Treasurer or Members.

(D) Powers and Duties of Assembly.

(1) Prior to _____ in each Fiscal Year, the Assembly shall determine, upon recommendation from the Board of Directors, the total estimated costs of operating the Council and its programs for the next Fiscal Year, separately identifying the costs of each program of the Council, and the portion of the total estimated costs of operating the Council and its programs to be allocated to each Member pursuant to Section 10 hereof.

(2) Prior to _____ in each Fiscal Year, the Assembly shall consider, upon submission by the Board of Directors, and thereafter modify, if necessary, and approve the annual appropriations of the Council for the next Fiscal Year.

(3) Prior to _____ in every other Fiscal Year, the Assembly shall select the officers of the Council and the other members of the Board of Directors for the next Fiscal Year in accordance with Section 3 hereof.

(4) The following matters shall be submitted to the Assembly and are subject to final approval by the Assembly: the total costs of operating the Council for each fiscal Year; selection of the Board of Directors; the apportionment among the Members of the costs of or surplus revenues derived from operating the Council; and such other matters as the Board of Directors or the Assembly may, from time to time, determine to be matters requiring approval by the Assembly.

Section 3. Board of Directors and Officers.

(A) Composition of Board of Directors. The Board of Directors shall be the managerial body of the Council. The Board of Directors shall be composed of seven individuals who shall be (1) a person with expertise or experience in education, (2) a person with expertise or experience in financial management, (3) a person with expertise or experience in telecommunications, (4) an attorney who may serve as general counsel to the Council, (5) a representative of the community at large who resides within a Member municipal corporation and who is not an elected official, (6) the Treasurer of the Council and (7) the Chairman of the Council (and in the absence of the Chairman, the Vice Chairman). The Board of Directors shall be elected by the Assembly from among those nominated by the Board of Directors.

The person serving as the Recording Secretary of the Council and, if the Council has an Administrator, the person serving as Administrator of the Council each shall be an ex-officio member of the Board of Directors and may attend all meetings of the Board of Directors but shall not count for purposes of determining a quorum and shall not have a vote. All members of the Board may serve with compensation.

(B) Officers. The officers of the Council shall be the Chairman, the Vice-Chairman, the Treasurer and the Recording Secretary and shall serve as officers for a two-year term commencing the first day of the Fiscal Year following their election as provided below.

(C) Election Procedures. The Assembly shall convene on or prior to _____ in every other Fiscal Year to elect the officers of the Council and to elect the members of the Board of Directors. The members so elected by the Assembly shall serve as members of the Board of Directors for a two-year term and the officers shall serve as officers for a two-year term. However, in order to stagger the terms of the Directors, for purposes of the first election held following the initial organization of the Council, the Chairman, the Treasurer and two other Directors shall serve as Directors for an initial term ending at the conclusion of the third Fiscal Year following their election and the remaining three Directors elected by the Assembly shall serve as Directors for an initial term ending at the conclusion of the second Fiscal Year following their election. Thereafter, any Director shall serve for a two-year term commencing on the Fiscal Year following election by the Assembly. There shall be no limit to the number of terms to which a person may be elected or appointed.

(D) Vacancies. In the event that a vacancy occurs in a position on the Board of Directors, the Board of Directors shall appoint an interim Director to serve as a Director for the balance of the term of office of the Director whose position was vacated or until another Director is elected by the Assembly in accordance with these Bylaws.

(E) Duties of Officers.

(1) Chairman. The Chairman shall preside at all meetings of the Board of Directors and the Assembly. The Chairman's duties shall also include, but not be limited to: preparing agendas for each meeting of the Board of Directors and presenting an annual report to the Assembly or distributing such report to the Members concerning the activities and operations of the Council.

(2) Vice-Chairman. In the absence of the Chairman, the Vice-Chairman shall preside at meetings of the Board of Directors and the Assembly. The Vice-Chairman shall succeed to the office of the Chairman, should that office be vacated before the end of a term, and shall assist the Chairman in the discharge of his duties.

(3) Recording Secretary. The Recording Secretary shall provide written notice to all members of the Board of Directors of all meetings of the Board in accordance with paragraph (F) of this Section and shall provide written notice to members of the Assembly of all meetings of the Assembly in accordance with Section 2. Minutes of all meetings of the Board shall be kept by the Recording Secretary and distributed to each member of the Board following each Board meeting. The Recording Secretary shall perform such other duties as the Chairman may request. The Recording Secretary may designate another person to keep minutes of Board meetings and to otherwise assist the Recording Secretary in carrying out the duties of that office.

(F) Meetings of Board of Directors. A majority of all members of the Board of Directors shall constitute a quorum to transact business. Each member of the Board of Directors shall have one vote.

Ex-officio members of the Board of Directors may attend all meetings of the Board of Directors but shall not be counted for purposes of determining a quorum and shall not have a vote.

All action of the Board of Directors shall be by resolution entered on its records. The affirmative vote of at least a majority of all members of the Board of Directors (not counting vacancies) shall be required for the enactment of every resolution. All resolutions shall be effective immediately upon enactment.

The Board of Directors shall meet at least four times each Fiscal Year. At its first meeting in each Fiscal Year, the Board of Directors shall set the dates for its regular meetings for that Fiscal Year. Additional meetings may be called by the Chairman as necessary or may be called upon written request to the Recording Secretary from any two or more members of the Board of Directors or from the Treasurer. Notice, in writing, of each such meeting shall state the date, time and place of the meeting and subject or subjects to be considered at the meeting, and shall be served by the Recording Secretary upon each member of the Board of Directors not less than 24 hours preceding the time for the meeting. The requirements and procedures for notice may be waived in writing by each member of the Board of Directors and any member of the Board of Directors shall be deemed conclusively to have waived such notice by his attendance at such meeting.

Pursuant to Revised Code Section 121.22(F), the Board of Directors shall, by rule, establish a reasonable method whereby any person may determine the time, place and purpose of its meetings. All meetings of the Board of Directors shall be open to the public, subject to

the exceptions in Revised Code Section 121.22(G). The Board of Directors may, but need not, adopt other rules.

(G) Powers and Duties. The Board of Directors shall have the authority to do the following:

(1) Consider and approve programs in which some or all Members may determine to participate.

(2) Act as the managerial body for the System and any other programs of the Council.

(3) Appoint one or more advisory committees, as provided in Section 6, if determined by the Board to be necessary or appropriate to assist the Board in the management of any program.

(4) Authorize the employment of employees of the Council as are determined to be needed for the operation and administration of the System and any other of the Council's programs and establish their salaries, benefits and work and disciplinary rules; provided that the compensation to be paid to any employee is within the budget approved by the Board of Directors in accordance with these Bylaws.

(5) Consider and approve any purchases, leases or other acquisitions of equipment, facilities or services for the Council and authorize the retention of the services of consultants or other independent contractors; provided that the cost thereof is within the budget approved by the Assembly or Board of Directors in accordance with these Bylaws.

(6) Direct the Treasurer concerning disbursements from the funds maintained by the Council.

(7) Amend the budget and appropriations of the Council, subject to certification by the Treasurer that the amended budget and appropriations are within the limits of the Council's resources.

(8) Make recommendations to the Assembly concerning any matter relating to the Council and its programs, including but not limited to: (a) amendments to or modifications of the Agreement and Bylaws, (b) appropriations of the Council, (c) each Member's share of the costs of operating the Council and its programs, (d) inclusion of additional Members in the Council and the provision of services by the Council to other entities under contract with the Council, and (e) disqualification of Members.

Section 4. Treasurer. The Treasurer, who shall meet the qualifications under Ohio law for fiscal officers of municipal corporations, who shall have the skills and experience necessary to perform the duties of the Treasurer of the Council and who shall not be affiliated with any Member, shall be elected in accordance with Section 3 of these Bylaws. In the event that such Treasurer should cease to serve as Treasurer for the Council, the Board of Directors shall select and authorize the appointment of another person to serve as Treasurer, subject to approval by the Assembly. The Board of Directors shall determine the compensation to be paid to the Treasurer, which shall be a cost of operating the Council and its programs to be approved by the Assembly pursuant to Section 10 and paid by the Members.

The Treasurer of the Council shall act as the fiscal agent for the System and for any other program of the Council if so designated by the corresponding program agreement. The Treasurer shall receive and disburse all funds of the Council, prepare all necessary fiscal reports for the Board of Directors, and undertake all other financial transactions necessary to the work of the Council.

The Treasurer shall obtain and keep in force a fidelity bond, in an amount determined by the Board of Directors and with a surety company approved by the Board of Directors, or, in lieu of a separate fidelity bond, the Board of Directors may direct the Treasurer to continue and keep in force any existing fidelity bond the Treasurer may have which the Board of Directors determines to be adequate. In either case, the Council shall be named as an insured on such bond and the amount thereof shall not be reduced without prior written consent of the Board of Directors.

Section 5. Administrator. The Board of Directors may appoint a person to serve as Administrator of the Council if the Board determines that an administrator is necessary for the efficient operation of the Council and its programs. The Administrator shall oversee the implementation of the Board's policies and directives with respect to the operation of the Council and the System and any of its other programs and perform such duties as may be determined by the Board of Directors to be the responsibility of the Administrator. The person appointed as Administrator shall have the educational background and prior work experience determined by the Board of Directors to be necessary to discharge the duties of the Administrator. The Board of Directors shall determine the compensation to be paid to the Administrator, which shall be a cost of operating the Council and its programs to be approved by the Assembly pursuant to Section 10 and paid by the Members.

Section 6. Advisory Committees. One or more advisory committees may be appointed by the Board of Directors to assist the Board of Directors in the management of the System and any other program of the Council. The members of an advisory committee shall be appointed by and shall serve at the pleasure of the Board of Directors and for such period of time as may be determined by the Board of Directors. The members of the advisory committees need not be the representatives of the Members in the Assembly; for example, advisory committees may be composed of treasurers, business managers or other officials or employees of the Members and employees of the Council or consultants and other persons who are not officers or employees of the Members of the Council. At least one member of the Board of Directors shall serve as liaison to each advisory committee. Each Advisory Committee shall perform the duties directed by the Board of Directors.

The Board of Directors shall appoint a chairman and vice-chairman for each advisory committee. The committee chairman shall preside at all committee meetings and prepare the agenda for each meeting following consultation with the Board of Directors. In the absence of the committee chairman, the committee vice-chairman shall preside at committee meetings. The committee vice-chairman shall succeed to the office of the committee chairman, should it be vacated before the end of a term, and shall assist the committee chairman in the discharge of the chairman's duties.

Each advisory committee shall make recommendations to the Board of Directors concerning any matter referred to it by the Board of Directors.

Section 7. Employees and Consultants. The Council may employ persons and may contract for the services of independent contractors, consultants or experts as the Board of

Directors deems necessary or appropriate for the proper operation and administration of the Council and its programs. Any staff employed by the Council shall be determined by the Board of Directors to have the educational background and work experience necessary to discharge the duties assigned to that person by the Board of Directors. The Board of Directors shall establish the salaries, benefits, and work and disciplinary rules for the Council's staff and shall direct the hiring and discharge of that staff. Each contract of employment shall be approved by the Board of Directors and shall be signed by the Chairman or Vice-Chairman of the Board of Directors and by the Treasurer. The Board of Directors of the Council may designate the Administrator to be responsible for the supervision of the Council's staff. The salaries and benefits paid to any employees of the Council and any amounts paid under contract to independent contractors, consultants or experts shall be operating costs of the Council and shall be payable solely from moneys on deposit in funds of the Council designated by the Board of Directors to be used for the payment of such costs.

Section 8. Equipment and Facilities. The Council may purchase, lease, lease with an option to purchase, or otherwise provide for supplies, materials, equipment and facilities as it deems necessary and appropriate to carry out the programs of the Council. The Council shall comply with the laws of the State of Ohio governing its Members with respect to the procedures for bidding and letting of contracts for the acquisition, repair or improvement of its facilities, equipment and supplies. All contracts or leases or lease-purchase agreements or other arrangements entered into by the Council for supplies, materials, equipment or facilities of the Council shall be approved by the Board of Directors and shall be signed by the Chairman or Vice Chairman of the Board of Directors and by the Treasurer. In the event that it is necessary for a Member of the Council to enter into a contract, lease, lease-purchase agreement or other arrangement for the acquisition of any equipment or facilities (e.g., in order to facilitate tax-exempt financing thereof), the contract, lease, or lease-purchase arrangement shall be approved by the Board of Directors before the Member enters into such obligation on behalf of the Members of the Council.

Section 9. Council Funds. The Council's funds shall be established and maintained by the Treasurer of the Council separate and apart from all other funds which may be under the custody of the Treasurer. One or more funds shall be established for the System and for any other program of the Council. The Council shall establish a separate fund (the "Council Fund") for the payment of overhead costs of the Council not solely attributable to any one program. Those overhead costs may be allocated to the various programs of the Council and moneys may be transferred from the various program funds to the Council Fund in such manner as may be authorized by the Board of Directors, consistent with the budget approved by the Assembly pursuant to Section 10 of these Bylaws. The Council Fund [and other funds of the Council] shall be subject to the laws of the State concerning the investment and management of public funds, particularly Revised Code Chapter 135, and shall be the responsibility of the Treasurer.

The Treasurer of the Council shall deposit in the Council Fund the contributions received from the Members or from other sources for operating costs of the Council. Any interest earned on moneys in the Council Fund shall be credited to the Council Fund. Disbursements may be made from the Council Fund by the Treasurer at the direction of the Board of Directors or the Assembly for any proper purpose of the Council, including but not limited to payment of operating costs, costs incurred in connection with the organization and meetings of the Council, costs and expenses of studies undertaken relating to new programs which may be of interest and benefit to Members of the Council, salaries of any staff employed by the Council (including the persons employed as the Treasurer and/or Administrator), fees and expenses of consultants and attorneys, and payment of other operating expenses.

The Treasurer of the Council shall maintain records which separately identify by Member all contributions from the respective Members for payment of costs of operating the Council and its programs. The Treasurer shall maintain records which account for all disbursements from the Council Fund. The Treasurer shall make monthly reports to the Board of Directors concerning all contributions to and disbursements from the Council Fund during the preceding calendar month.

Section 10. Estimate of Council Costs; Payments by Members. Although it is not anticipated that Member municipal corporations will need to contribute moneys for costs of the Council or its programs, if circumstances require such contributions from Members, the provisions of this Section 10 shall govern.

Prior to _____ preceding the Fiscal Year for which the following estimates are made, the Board of Directors shall: (a) submit to the Assembly a written estimate of the costs of operating the Council and its programs for the next Fiscal Year, separately itemized for each program of the Council, and (b) provide the Assembly and each Member with an estimate of each Member's share of those costs, separately itemized for each program in which that Member participates. The costs of the System shall be apportioned among all Members as provided in the System Agreement, and the costs of any other program shall be apportioned among the Members participating in the program as provided in the written agreement for each program. Any costs relating to the operation of the Council and not included in program costs shall be apportioned among the Members in the manner determined by the Board of Directors. The estimates shall be presented in enough detail so that the Assembly can determine their sufficiency.

The Assembly shall consider the estimates and accept or modify the same and thereby authorize and approve the estimated budget and appropriations for the Council. It shall then instruct the Treasurer to deliver to the Members, on or before _____, an estimated budget of the Council for the next Fiscal Year evidencing each Member's share of that budget. Each Member shall include its share of that budget in its own tax budget submitted to the County Budget Commission.

On or before _____ in each Fiscal Year the Assembly shall consider, upon submission by the Board of Directors, and modify, if necessary, and approve the annual budget and appropriations of the Council for the next Fiscal Year. The budget and appropriations for the Council may thereafter be amended, if necessary or appropriate, by resolution of the Assembly, or if such amendments do not increase the payments to be made by the Members, by resolution of the Board of Directors.

Each Member shall, on or before _____ of the Fiscal Year of the Council for which that estimate was made, appropriate (pursuant to Chapter 5705 of the Revised Code) its share of the Council costs included in the Council's annual budget. Each Member shall thereafter (a) remit to the Treasurer its share of the costs of the System and any other programs in which it participates in the manner provided in the respective written agreements for those programs and (b) remit to the Treasurer its share of other costs of the Council in the amounts and at the times directed by the Treasurer.

If the aggregate of the contributions made pursuant to that budget prove to be insufficient to pay the costs of operating the Council [and its programs] for that Fiscal Year of the Council, the Board of Directors shall direct the Treasurer to promptly notify in writing each Member of any additional costs of operating the Council [and its programs], the amount of any

deficiencies and each Member's share of those additional costs, all as determined by the Board of Directors, whereupon each Member shall appropriate (pursuant to Chapter 5705 of the Revised Code) the amount stated in that notice and remit the same to the Treasurer within the time periods determined by the Board of Directors.

Failure by a Member to appropriate and remit any of its share of the costs of operating the Council and its programs pursuant to these Bylaws within ___ days after the same shall become due shall be deemed a withdrawal by such Member from the Council unless the Member has petitioned the Board of Directors for an extension of time for payment and the Board of Directors has, by resolution, approved an extension to a date certain and the Member has remitted its share of the those costs to the Treasurer within the time extension(s) approved by the Board of Directors.

Under no circumstances shall the Treasurer have the power to incur obligations for costs of operating the Council and its programs in an amount which exceeds the total unspent amount appropriated for those costs and remitted to the Treasurer by the governing bodies of the Members (or in the process of collection by the Treasurer from the Members or other sources), all pursuant to the Agreement, the Bylaws and the program agreements, except as may be permitted by law.

Section 11. Conduct of Meetings. All meetings provided for in these Bylaws shall be conducted in accordance with the latest edition of Robert's Rules of Order, Revised unless otherwise directed by these Bylaws or by resolution of the Assembly, the Board of Directors, or any advisory committee with respect to the meetings of each of those bodies. The Chairman of the Council (and, in the case of an advisory committee, the committee chairman) shall be the parliamentary procedure officer and his decisions with respect to matters of parliamentary procedure shall be final.

Section 12. Amendments. These Bylaws may be modified, amended or supplemented in any respect upon approval of the modification, amendment or supplement by at least a majority of the Members' representatives in the Assembly and the approved amendment, modification or supplement shall thereupon become binding upon all Members.

Section 13. Transition. In the first Fiscal Year of the Council's operations, actions required by these Bylaws to be taken by the Assembly or the Board of Directors prior to specified dates shall be taken as soon as practical following the effective date of the Agreement and Bylaws.

ADOPTED this _____ day of _____, 199__.

OHIO TELECOMMUNICATIONS NETWORK COUNCIL

Recording Secretary

RESOLUTION ACCEPTING THE AMOUNTS AND RATES AS DETERMINED BY THE BUDGET COMMISSION AND AUTHORIZING THE NECESSARY TAX LEVIES AND CERTIFYING THEM TO THE COUNTY AUDITOR

(CITY COUNCIL)

Rev. Code, Secs. 5705.34, 5705.35

Resolution No. 97-180
By: Kenneth Kovach

The Council of the City of SHAKER HEIGHTS, CUYAHOGA County, Ohio, met in Regular session on the 24th day of November, 1997, at the office of Council Chambers, City Hall with the following members present:

- Mr. Allen Foster
Ms. Margaret Jorgensen
Mr. Kenneth Kovach
Ms. Jan Devereaux
Ms. Stephanie Turner

Mr. Kenneth Kovach moved the adoption of the following Resolution:

WHEREAS, This Council in accordance with the provisions of law has previously adopted a Tax Budget for the next succeeding fiscal year commencing January 1st, 1998; and

WHEREAS, The Budget Commission of CUYAHOGA County, Ohio, has certified its action thereon to this Council together with an estimate by the County Auditor of the rate of each tax necessary to be levied by this Council, and what part thereof is without, and what part within the ten mill tax limitation; therefore be it

RESOLVED, By the Council of the City of SHAKER HEIGHTS, CUYAHOGA County, Ohio, that the amounts and rates, as determined by the Budget Commission in its certification, be and the same are hereby accepted; and be it further

RESOLVED, That there be and is hereby levied on the tax duplicate of said City the rate of each tax necessary to be levied within and without the ten mill limitation as follows:

19 . for not to exceed years.

Fund: Levy authorized by voters on

19 . for not to exceed years.

and be it further

RESOLVED, That the Clerk of this Council be, and he is hereby directed to certify a copy of this Resolution to the County Auditor of said County.

Ms. Margaret Jorgensen seconded the Resolution and the roll being called upon its adoption the vote resulted as follows:

Mr. Allen Foster	Aye
Ms. Margaret Jorgensen	Aye
Mr. Kenneth Kovach	Aye
Ms. Jan Devereaux	Aye
Ms. Stephanie Turner	Aye
Mr.	
Ms.	

Adopted the 24th day of November 19 97

Attest:

Patricia S. Mearns, Mayor President of Council

William J. Schuchart, Clerk of Council

CERTIFICATE TO COPY

ORIGINAL ON FILE

The State of Ohio, Cuyahoga County, ss.

I, William J. Schuchart, Clerk of the Council of the City of Shaker Heights, within and for said County, and in whose custody the Files and Records of said Council are required by the Laws of the State of Ohio to be kept, do hereby certify that the foregoing is taken and copied from the original Resolution 97-180

now on file, that the foregoing has been compared by me with said original document, and that the same is a true and correct copy thereof.

WITNESS my signature, this 25th day of November, 1997

William J. Schuchart Clerk of Council

1. A copy of this Resolution must be certified to the County Auditor before the first day of October in each year, or at such later date as may be approved by the Board of Tax Appeals.

No.

COUNCIL OF THE CITY OF

Shaker Heights

Cuyahoga

County, Ohio

RESOLUTION

ACCEPTING THE AMOUNTS AND RATES AS DETERMINED BY THE BUDGET COMMISSION AND AUTHORIZING THE NECESSARY TAX LEVIES AND CERTIFYING THEM TO THE COUNTY AUDITOR.

(City Council)

Adopted November 24, 1997

William J. Schuchart Clerk of Council

Filed, 1997

County Auditor

Deputy

ORDINANCE NO. 97-181
BY: Jan Devereaux

Establishing as a Special Revenue Fund, Alternate Dispute Fund, in the fund accounts of the City.

BE IT ORDAINED by the Council of the City of Shaker Heights, State of Ohio:

Section 1. That there be and is hereby created the following Special Revenue Fund Account of the City.

Fund No. 218 Alternate Dispute Fund

Section 2. The monies in said fund shall henceforth be deemed appropriated by the City of Shaker Heights and shall be disbursed only upon the approval by authorized parties of the vouchered claim according to the procedures as may hereafter be set forth.

Section 3. This ordinance is hereby declared to be an emergency measure necessary for the immediate preservation of the public peace, health, safety and welfare for the reason that it is necessary in the current operation of the City and, therefore, this ordinance shall take effect immediately upon its enactment and approval by the Mayor.

Enacted November 24, 1997.

Approved this 25th day of November, 1997.

PATRICIA S. MEARNs, Mayor

Attest:

WILLIAM J. SCHUCHART
Clerk of Council

ORDINANCE NO. 97-182
BY: Kenneth J. Kovach

Authorizing an agreement for an Employee Assistance Program (Foundation Health PsychCare Services, Inc., dba Occupational Health Services).

BE IT ORDAINED by the Council of the City of Shaker Heights, State of Ohio:

Section 1. This Council hereby authorizes the Mayor and the Director of Finance to enter into an agreement with Foundation Health PsychCare Services, Inc., dba Occupational Health Services, for an Employee Assistance Plan and services, effective November 15, 1997. Said agreement shall be in substantially the form as attached hereto and included herein by reference, as approved by the Director of Law.

Section 2. The agreement authorized herein shall be for a period of one year, but may be renewed annually by the City, so long as any increase in the rates for the services authorized herein are approved by City Council, which approval may be given as part of Council's review and approval of the City's annual budget.

Section 3. This ordinance is hereby declared to be an emergency measure necessary for the immediate preservation of the public peace, health, safety and welfare for the reason that it is necessary in the current operation of the City and, therefore, this ordinance shall take effect immediately upon its enactment and approval by the Mayor.

Enacted November 24, 1997.

Approved this 25th day of November, 1997.

PATRICIA S. MEARNS, Mayor

Attest:

WILLIAM J. SCHUCHART
Clerk of Council

AGREEMENT FOR EMPLOYEE ASSISTANCE PROGRAM SERVICES

This Agreement for Employee Assistance Program Services is entered into and is effective as of this 15th day of November, 1997, by and between Foundation Health PsychCare Services, Inc. dba Occupational Health Services, a California corporation, 1600 Los Gamos Drive, Suite 300, San Rafael, California, 94903 (hereinafter referred to as "FHPS") and the City of Shaker Heights, an Ohio municipal corporation, 3400 Lee Road, Shaker Heights, Ohio, 44120 (hereinafter referred to as "Employer").

IT IS AGREED:

I. SCOPE OF SERVICES TO BE RENDERED: FHPS will provide during the period beginning November 15, 1997 and ending November 14, 1998, the following specific services at FHPS designated office locations or mutually agreed upon facilities and/or locations. Included among the services to be provided by FHPS are the following:

A. Provision of management consultation relative to the development and integration of organizational policies and procedures necessary for effective Employee Assistance Program implementation.

B. Provision of program materials to include brochures, posters and payroll stuffers.

mjw
C. Provision of ^{if} critical incident ^{de-} briefing, employee orientations, supervisory training sessions and/or group counseling upon request at no additional charge.

D. Provision of assessment and referral counseling to Employer's eligible employees desiring such services, utilizing licensed professional staff to identify and evaluate personal problems and concerns and to assess and develop options for alternatives for the resolution of such problems as may exist from time to time among Employer's employees. Such direct counseling shall provide for up to three (3) sessions per incident per family member. Employee counseling exceeding three (3) assessment and referral sessions will become the financial responsibility of the Employee unless otherwise arranged for by the Employer.

E. Management Consultation. FHPS will provide unlimited Management Consultation Services to Employer's managers and supervisors, including training in basic techniques for identifying the cause of job performance problems, analyzing those problems, and using existing resources, including the EAP plan, to develop workable solutions. In addition, FHPS will provide referral sessions focusing on the work performance problem motivating the referral. These sessions are in addition to the assessment and referral counseling sessions described in paragraph ~~E~~ above.

F. Provision of four (4) "Brown Bag" seminars at no additional charge. *D mjw*

G. Provision of referral services to professional community resources for treatment and/or assistance as may be appropriate.

H. Provision of quarterly statistical evaluation of program activity and such other information as may be reasonably requested by the Employer, not inconsistent with Section IV. of this Agreement.

II. ELIGIBILITY:

A. **Employee:** An individual who is a permanent full-time or permanent part-time employee working 30 hours or more per week.

B. **Dependent:** The lawful spouse and unmarried dependent children who are 23 years of age or less; and the unmarried dependent children over the age of 23 who are incapable of self-sustaining employment by reason of mental retardation or physical handicap. The term "children" as used herein includes stepchildren, legally adopted children for whom either parent is the legal guardian or any children which by court order must be provided health care coverage by the Subscriber or the Subscriber's spouse. To be considered eligible dependents they must be allowed as Federal Income Tax exemptions.

III. NOTICES

Any notice required to be given regarding this Agreement shall be considered effectively given when personally delivered or mailed by prepaid certified mail, return receipt requested, addressed as follows or to such other address as the parties may later specify in writing. Employer agrees to cooperate with FHPS in disseminating to Subscribers any disclosure forms or other material that may be required to be disseminated to Employees.

To Employer: City of Shaker Heights
Attention: Mary Gavin-Wagner, HR & Risk Manager
3400 Lee Road
Shaker Heights, Ohio 44120
Telephone: (216) 491-1416
FAX: (216) 491-1465

To FHPS: Foundation Health PsychCare Services, Inc. dba Occupational Health Services
Attention: President
1600 Los Gatos Drive, Suite 300
San Rafael, California 94903
Telephone: (415) 491-7200
FAX: (415) 472-8184

IV. CONFIDENTIALITY:

A. Records, including any information whether recorded or not, pertaining to the identity, diagnosis or treatment of any Employee or Dependent which are maintained in connection with the performance of this Agreement shall be confidential and disclosed only in accordance with all applicable state and federal laws and regulations, including those relating to the confidentiality of medical records, patient consents to release information, the psychotherapist-patient privilege, and drug and alcohol program records.

B. FHPS agrees to operate a system of records on individuals in accordance with the Privacy Act of 1974, as amended.

V. COMPENSATION BY EMPLOYER:

A. **Quarterly Prepayment Fees.** Prepayment fees payable by Employer to FHPS are calculated on a capitated basis based on the number of employees enrolled as of the first day of each quarter during the term of this Agreement as follows:

\$2.70 per Employee per month.

B. **Time for Payment.** Employer shall promptly pay to FHPS the foregoing quarterly prepayment fees on or before the first day of the quarter. Payments shall be made to Occupational Health Services and sent to Attention: Lockbox, Dept. 098-61, P.O. Box 45110, San Francisco, California 94145-0110.

C. **Prepayment Fees Payable by Employees.** Employer shall determine what portion, if any, of the prepayment fees shall be contributed by Employees, either by payroll deduction or by direct payment. Employer is responsible for the collection of such contributions unless other arrangements acceptable to FHPS are made.

D. **Eligibility Information.** Employer shall furnish accurate, current and timely eligibility information (including Medicare eligibility related information) to FHPS. FHPS may rely upon the latest information received as correct without further verification. If Employer submits inaccurate information to FHPS, Employer is responsible for prepayment fees associated with the periods of time and coverages extended based on the accurate information. FHPS will not refund prepayment fees to Employer paid for an ineligible person if: (a) the request for such refund is made later than 30 days after the receipt of payment by FHPS for said ineligible person; OR (b) Covered Services were received by the ineligible person during such period. FHPS reserves the right to verify eligibility data maintained by Employer as they relate to establishment and maintenance of eligibility for FHPS membership, provided, however, that such right shall be limited to the extent permitted by law and the requirement for confidentiality of Employee information is upheld.

E. **Change in Consideration.** The amount of the quarterly prepayment fees and other consideration for any annual period subsequent to the first contract year may be determined and changed at the end of any contract year by FHPS, provided, however, that Employer shall be notified of any change at 30 days in advance of the effective date. Payment of any quarterly prepayment fees as changed shall constitute acceptance of continued coverage at such changed rate.

F. **Interest Charges on Amounts in Arrears.** Prepayment fees not paid by the due date specified above shall bear an interest charge of one percent (1%) per month for all amounts unpaid.

G. **Eligibility Changes Requested by Employer.** All eligibility provision changes which are requested by Employer to be implemented prior to the anniversary date of this Agreement are subject to FHPS' prior written consent, which may be withheld for any reason at the sole

discretion of FHPS. The parties acknowledge that there may be a resulting concomitant increase to the prepayment fees required under this Agreement if the eligibility change would increase the size of the group's risk pool or otherwise change the nature of the risk from that which the original rates were contemplated.

VI. INSURANCE:

A. FHPS agrees to provide, at its own cost during the term of this Agreement, professional liability insurance with limits of not less than Two Million Dollars (\$2,000,000) per occurrence and Six Million Dollars (\$6,000,000) in the aggregate and general liability of not less than One Million Dollars (\$1,000,000) for bodily injury or death of one or more persons arising out of the same accident or occurrence. FHPS agrees, upon the written request of Employer, to provide a written certificate of said insurance, which shall certify that the said policies provide that said insurance shall not be canceled or changed except upon thirty (30) days prior written notice thereof to Employer.

B. Additional Insured Coverage Under FHPS's Professional Liability Policy. FHPS agrees during this and all subsequent contract periods to hold harmless, indemnify and defend Employer, its officers, agents and employees from and against any and all claims, up to a total of Two Million Dollars (\$2,000,000) arising out of the injury, death or loss to any person resulting from the negligence of FHPS, its officers, agents or employees, which may occur in connection with this Agreement, except to the extent of any such liability resulting from the negligence or willful or intentional misconduct of Employer, its officers, agents or employees.

VII. TERMS:

A. The term of this Agreement shall be for one (1) year.

B. This Agreement shall be renewed for additional one (1) year terms upon both parties serving written notice of renewal to the other more than thirty (30) days prior to the expiration of the first or any subsequent term. This Agreement may be renewed on the same terms and conditions as it presently contains, provided that the compensation specified in Section V. may, by mutual agreement be changed. Notwithstanding the provisions of this Section, the parties may negotiate new and different terms or conditions, or a different level of compensation, in light of legislative or regulatory changes that require FHPS to change the terms or conditions or to offer additional benefits not covered by this Agreement. Such changes shall be effective on the anniversary date of this Agreement unless otherwise mandated by law.

C. Unless otherwise specified in Section I, any individual term of one (1) year's duration shall be considered a "contract period" as that term is used in this Agreement.

D. Individual Continuation of Benefits. An individual Employee does not have the right to renew his or her eligibility for Program Services once his or her relationship (employment or otherwise) to Employer is terminated. An Employee's right to receive Program Services is determined solely by the Employee's Employer.

IX. GENERAL PROVISIONS: ENTIRE UNDERSTANDING - This Agreement contains the entire understanding of the parties hereto relating to the subject matter herein contained and supersedes all prior and collateral agreements, understandings and negotiations of the parties. Each party acknowledges that no representation, inducements, promises or agreements, oral or written, with reference to the subject matter hereof have been made other than as expressly set forth herein. This Agreement cannot be changed, rescinded or terminated orally.

IN WITNESS WHEREOF, the parties hereto have executed this Agreement as of the day and year first herein above set forth.

**FOUNDATION HEALTH PSYCHCARE SERVICES, INC. dba
OCCUPATIONAL HEALTH SERVICES**

By:  Signed in the presence: _____

Title: Dave Buhler, Senior Vice President, Finance

Date: 10/10/07

CITY OF SHAKER HEIGHTS

By: _____ Signed in the presence of: _____

Title: _____
Director of Finance

Date: _____

Approved as to form: _____
Director of Law

ORDINANCE NO. 97-183
BY: Jan M. Devereaux

Amending Section 547.03 of the Business Regulation Code relative to the requirements for the Certificate of Contractor Registration.

BE IT ORDAINED by the Council of the City of Shaker Heights, State of Ohio:

Section 1. Section 547.03 of the Business Regulation Code, relative to the registration of contractors, and titled "Requirements For Certification," is hereby amended to read as follows:

547.03 REQUIREMENTS FOR CERTIFICATION.

(a) An application for a Certificate of Contractor Registration shall be filed each year with the Commissioner of Buildings. An application may be filed no sooner than December 1 of the year preceding the time of registration.

(b) The application shall include the following:

(1) An application form requiring:

- A. The name, address, business and home telephone numbers, and social security number or federal employer identification number of the applicant;
- B. The name, address and social security number of each employee and subcontractor of the applicant who are currently working on any site in the City;
- C. The name, address and social security number of each employee and subcontractor of the applicant who worked on any site in the City during the calendar year preceding the year of registration, provided that, in the case of an applicant which files its application prior to January 31 of the year of registration, the Commissioner of Buildings may issue a Certificate of Registration on condition that the applicant submits this information no later than January 31 and if the information is not so submitted, the Commissioner may suspend the conditional Certificate of Registration until such time as the information is submitted, upon giving written notice to the contractor as provided in Section 547.04(b);
- D. A list of current licenses held by the applicant from governmental entities within Cuyahoga County or contiguous counties, with certified copies of the licenses attached (for electrical, plumbing and sewer contractors, the Commissioner of Buildings shall require that the applicant has a license from a governmental agency in Cuyahoga County or contiguous counties which has given a competent qualifying examination);

E. A list of the names, addresses and telephone numbers of municipalities within Cuyahoga County or contiguous counties where the applicant has done work.

- (2) A certificate of insurance naming the City and its agents as additional insured parties in the minimum amounts of one hundred thousand dollars (\$100,000) per person and three hundred thousand dollars (\$300,000) per occurrence for bodily injury and fifty thousand dollars (\$50,000) per occurrence for property damage.

Section 2. Section 547.03 of the Business Regulation Code, as heretofore in effect, is hereby repealed.

Section 3. This ordinance is hereby declared to be an emergency measure necessary for the immediate preservation of the public peace, health, safety and welfare for the reason that it is necessary in the current operation of the Building Department and, therefore, this ordinance shall take effect immediately upon its enactment and approval by the Mayor.

Enacted November 24, 1997.

Approved this 25th day of November, 1997.

PATRICIA S. MEARNS, Mayor

Attest:

WILLIAM J. SCHUCHART
Clerk of Council

ORDINANCE NO. 97-184
BY: Jan M. Devereaux

Amending Ordinance No. 97-160, authorizing a contract with Fifth Third Bank relative to a home improvement and repair program.

WHEREAS, this Council enacted Ordinance No. 97-160 on September 22, 1997, which authorized a contract between the City and Fifth Third Bank relative to a home improvement and repair program, which contract was also approved by Fifth Third Bank; and

WHEREAS, the contract so approved was attached to Ordinance No. 97-160; and

WHEREAS, in accordance with said contract, Fifth Third Bank would only charge a loan fee to a borrower whose income exceeded 100% of the current Shaker Heights Median Income, as established by Exhibit C, and which Exhibit indicated a graduated median income from \$38,500 (one person household) to \$133,000 (8 person household); and

WHEREAS, apparently Fifth Third Bank, upon further review, determined that it had not intended to forego the charging of a loan fee for those persons whose income exceeded a Shaker Heights Median Income of \$51,124; and

WHEREAS, after further negotiation, the parties have agreed that a loan fee of \$180.00 may be charged by Fifth Third Bank to defray the costs of appraisal, attorneys fees and title work, to borrowers whose total income exceeds the Shaker Heights Median Income of \$51,124.08, adjusted annually; and

WHEREAS, the proposed contract approved by City Council pursuant to Ordinance No. 97-160 has been modified accordingly to reflect the change relative to the loan fee, as described herein; and

WHEREAS, the proposed contract, as modified, is attached hereto and included herein by reference, and no other substantive modifications have been made to the contract approved pursuant to Ordinance No. 97-160.

NOW, THEREFORE, BE IT ORDAINED by the Council of the City of Shaker Heights, State of Ohio:

Section 1. Ordinance No. 97-160, enacted by City Council on September 22, 1997, and which authorized a contract with Fifth Third Bank relative to a home improvement and repair program, is hereby amended by substituting the contract attached hereto, and included herein by reference, with the contract attached to Ordinance No. 97-160. In all other respects Ordinance No. 97-160 shall remain in full force and effect.

Section 2. This ordinance shall take effect from and after the earliest time allowed by law.

Enacted December 8, 1997.

Approved this 9th day of December, 1997.

PATRICIA S. MEARNS, Mayor

Attest:

WILLIAM J. SCHUCHART
Clerk of Council

AGREEMENT

BETWEEN THE CITY OF SHAKER HEIGHTS, OHIO, AND FIFTH THIRD BANK OF NORTHEASTERN OHIO FOR THE PROVISION OF HOME IMPROVEMENT AND REPAIRS LOANS.

This AGREEMENT, made at Shaker Heights, Ohio, as of the ____ day of _____, 1997, by and between the CITY OF SHAKER HEIGHTS, an Ohio municipal corporation, 3400 Lee Road, Shaker Heights, Ohio 44120, (216) 491-1400, (hereinafter designated the "CITY"), and FIFTH THIRD BANK OF NORTHEASTERN OHIO, (hereinafter designated the "BANK").

WITNESSETH:

For the mutual considerations herein described, the parties hereto agree as follows:

1. The CITY will deposit the sum of ONE HUNDRED THOUSAND DOLLARS (\$100,000) (the "Principal") in an interest-bearing account of the BANK, by no later than _____, 1997. Interest upon the Principal will accrue based upon the rate established for the Bank's Public Funds Sweep Account, adjusted quarterly. The CITY's Principal will remain deposited in the Public Sweeps Account at the BANK for period of two (2) years from the date of this AGREEMENT, subject to the terms and conditions of Paragraph 2 below.

2. The BANK agrees to apply the interest accrued upon said Principal, or portion thereof as necessary, to subsidize BANK loans for home improvements and repairs in Shaker Heights, so as to achieve a fixed loan rate of five percent (5%) for borrowers meeting the criteria established by the CITY and attached hereto as Exhibit A. It is understood and agreed that the BANK will transfer no more than fifty percent (50%) of the total amount of each loan closed from the Public Funds Sweep Account into a non-interest bearing subsidy account ("Subsidy Account") which will accrue interest at the Bank's Reinvestment Rate, adjusted quarterly. The Subsidy Account will be used by the BANK to compensate for the difference in interest between the 5% subsidized interest rate the borrower is to be charged by the BANK through the Shaker Heights Loan Program and the Home Improvement Market Rate (hereinafter defined) which is the actual interest rate the BANK will be charging and for which the Subsidy Account will be providing such compensation. The BANK will calculate how much subsidy will be required to offset the interest rate at the time the BANK closes the loan. The BANK will then transfer the sum needed into the Subsidy Account. In no event may the BANK require or transfer more than 50% of the loan amount. In the event the amount needed to subsidize the interest rate according to the BANK exceeds 50% of the loan amount, the BANK agrees to absorb the difference. At the start of each quarter, the BANK will recompute the required City subsidy which will be based on the average daily balance of the loans for the previous quarter and the BANK's current quarter Reinvestment Rate. It is understood and agreed that loan subsidy requirements will be computed based upon the month of maturity of a loan, not the day of maturity of a loan.

3. Neither this provision nor this contract shall be construed to constitute a promise or commitment by the CITY to guarantee repayment of any loans provided by the BANK pursuant to this contract, nor shall the CITY's Principal, or any portion thereof, be applied as a subsidy or guarantee of any such loan, except as provided in Paragraph 5 below.

4. The BANK will charge borrowers an interest rate based upon the Bank's current Home Improvement Market Rate, adjusted quarterly as of the first day of January, April and August of each year. This rate will be subsidized as described in paragraph 2 and illustrated in Exhibit B attached hereto and made a part hereof. No loan fee may be charged by the BANK on any loan, provided a borrower does not exceed 100% of the Shaker Heights Median Income, as shown on Exhibit C, subject to updating by The CITY annually. In the event a borrower's income exceeds the Shaker Heights Median Income listed on Exhibit C, as same is adjusted annually, the BANK may charge the borrower a fee not to exceed \$180.00 to defray the costs of appraisal, attorneys fees and title work. This fee may be financed as part of the loan. No service fee may be charged by the BANK to the CITY. The CITY will not be responsible for the processing of any loan, provided, however, it is understood and agreed that the CITY will be monitoring all work to be done by or on behalf of the borrower. The CITY will review the specifications and scope of work requested by the borrower. Both the BANK and the CITY will proceed with the loans in accordance with the procedures established in Exhibit A. The BANK will release no funds to the borrower unless and until the Department of Planning and Development advises the BANK in writing that the work was done satisfactorily. The proceeds of each loan shall be paid in the name of the borrower by the BANK. The BANK will require that all contractors must provide the property owner with lien release certificates that all materialmen, laborers, and subcontractors have been paid or have delivered releases of their rights to assert mechanic's liens upon the property before any funds are disbursed for work performed.

5. Within 30 days after each calendar quarter, the BANK will provide to the CITY comprehensive quarterly written reports containing information related to loan activity and loan payments by borrowers including, but not limited to, names, addresses, monthly amount of borrower's loan payments, compensating loss balance, type of work and status. Such reports shall be in a form as approved by the CITY. The BANK will provide to the CITY a monthly list of borrowers (approved and denied) and an explanation regarding denial. The BANK agrees to secure a release from each borrower so that it may provide such information to the CITY. This paragraph and its terms shall survive the termination of this Agreement until all loans are repaid. It is understood that in the event the BANK is not willing to loan funds because of poor credit history or other concerns, it shall inform the CITY, the CITY shall have the right to request to guarantee such loan. In the event the BANK agrees, the CITY shall deposit a maximum of 50% of the outstanding Principal of the loan into a separate account at the BANK as such guarantee. The BANK hereby agrees not to refuse any reasonable request by the CITY.

6. Delinquent loans may be subject to collection procedures instituted by the BANK in accordance with banking custom and applicable state and federal law, provided: (a) the CITY is given written notice of a delinquency; and (b) within ten (10) days after such notice, possible CITY intervention or other measures taken by or on behalf of the borrower have not remedied the default. The foregoing notwithstanding, the BANK may institute a foreclosure proceeding after ninety (90) days from the date the loan is past due, as the BANK deems appropriate. The BANK may, in its reasonable discretion, charge reasonable and customary collection fees on to borrower on delinquent loans. In the event a loan is guaranteed by the CITY, for loans with an outstanding Principal not to exceed \$2,000, a default for the purposes of this AGREEMENT only is defined as a total of three (3) full payments in arrears. Before the CITY will pay the guarantee, the BANK must seek and obtain a valid deficiency judgment from the court. The amount of the guarantee shall be 50% of the outstanding Principal balance, reduced by one-half of any funds recouped by the BANK. For loans with an outstanding Principal greater than \$2,000, the BANK must pursue full legal foreclosure before the CITY will pay the guarantee. In this event, the proceeds of any sale shall be applied first to interest, second to principal, and lastly to BANK costs.

7. The BANK agrees that the loans authorized pursuant to this contract will conform to all applicable state and federal laws, including but not limited to Fair Housing laws, and further, that it will not discriminate in the processing, issuance or administration of such loans on the basis of race, color, creed, national origin, ancestry, age, sex, familial status, or handicap.

8. This AGREEMENT is renewable only upon written agreement of the parties. Either party hereto shall have the right and option to cancel this AGREEMENT for any cause whatsoever upon the giving of at least ninety (90) days prior written notice of one party to the other. In the event of a cancellation, a) the BANK agrees to continue to service open loans until they are paid in full and b) the CITY shall have the right to remove any unobligated fund balance.

This AGREEMENT shall be deemed to contain all the terms and conditions agreed to between the parties, who both agree that no representations or promises of any kind whatsoever have been made other than herein contained, and this AGREEMENT shall be binding upon both parties and their respective heirs, administrators, executors, successors, and assigns.

IN WITNESS WHEREOF, the parties to this AGREEMENT have hereunto set their hands as of the day and year first above written.

Signed in the presence of:

**FIFTH THIRD BANK OF
NORTHEASTERN OHIO**

Emily P. Brady By Donald Graham S.V.P.
Quana Jones And Louise J. Gussendane AVP

THE CITY OF SHAKER HEIGHTS

_____ By _____
Mayor
_____ And _____
Director of Finance

APPROVED AS TO FORM:

By _____
Director of Law

DRAFT 10/22/97

LIST OF EXHIBITS

Exhibit A	Term Definition, Criteria and Credit Guidelines
Exhibit B	Rate Subsidy Illustration
Exhibit C	Income Eligibility Chart

EXHIBIT A

TERM: Maximum fifteen (15) years

INTEREST: Shall be determined and calculated by the following:

- a) **Loan Rate to Borrower:** the Bank's Home Improvement Market Rate, adjusted to five (5%) percent annual percentage rate.
- b) **City Principal:** rate established for the Bank's Public Funds Sweep Account, adjusted quarterly.
- c) **Subsidy Rate:** rate established for the Bank's Reinvestment Rate, adjusted quarterly which will be credited to City for funds held in a non-interest bearing Subsidy Account used to offset the interest loss on the borrower's 5% rate.
- d) **Unsubsidized Loan Rate to Borrower:** rate established for the Bank's Home Improvement Market Rate, adjusted quarterly.

AMOUNT OF LOAN: UP TO \$30,000

CRITERIA:

The BANK shall provide home improvement loans to approved loan applicants in Shaker Heights whose income is at or below 100% of the Shaker Heights Median Income, subject to adjustment annually by the CITY. The BANK shall determine income eligibility for the borrower based on the following chart:

INCOME ELIGIBILITY

1 person household	\$ 38,500
2 person household	51,000
3 person household	74,000
4 person household	89,500
5 person household	98,500
6 person household	108,500
7 person household	120,000
8 person household	133,000

The BANK understands and agrees that the CITY must approve the scope and type of work to insure that such work is in keeping with the quality and type of work which the CITY is prepared to subsidize. To that end, the borrower must obtain two bids from registered City contractors (if the work to be performed requires such registration). Once the CITY has reviewed the specifications for the work, the CITY will forward to the BANK an authorization to proceed once the CITY has approved the scope of work. The CITY will monitor the work through procedures that the CITY establishes from time-to-time. The CITY shall have the right to modify the loan criteria stated in this Exhibit A from time-to-

in its discretion, provided the CITY gives the BANK thirty (30) days notice of such changes. The BANK will release funds only in accordance with Paragraph 4 of this AGREEMENT.

CREDIT GUIDELINES

The BANK will use special credit guidelines for this loan program which includes a debt ratio guide as follows:

Gross Annual Income	Gross Monthly Income	Ratio Guide
\$40,000 or less	\$3,333 or less	41%
\$40,001 and up	\$3,334 or more	44%

Non traditional references will be considered, i.e., payment of utilities, rent, etc. Applicant should have a clean credit history for the last 24 months. Bankruptcies must have been discharged for at least three years.

1st Reading 11/24/97

ORDINANCE NO. 97-184
BY: Jan M. Devereaux

Amending Ordinance No. 97-160, authorizing a contract with Fifth Third Bank relative to a home improvement and repair program.

WHEREAS, this Council enacted Ordinance No. 97-160 on September 22, 1997, which authorized a contract between the City and Fifth Third Bank relative to a home improvement and repair program, which contract was also approved by Fifth Third Bank; and

WHEREAS, the contract so approved was attached to Ordinance No. 97-160; and

WHEREAS, in accordance with said contract, Fifth Third Bank would only charge a loan fee to a borrower whose income exceeded 100% of the current Shaker Heights Median Income, as established by Exhibit C, and which Exhibit indicated a graduated median income from \$38,500 (one person household) to \$133,000 (8 person household); and

WHEREAS, apparently Fifth Third Bank, upon further review, determined that it had not intended to forego the charging of a loan fee for those persons whose income exceeded a Shaker Heights Median Income of \$51,124; and

WHEREAS, after further negotiation, the parties have agreed that a loan fee of \$180.00 may be charged by Fifth Third Bank to defray the costs of appraisal, attorneys fees and title work, to borrowers whose total income exceeds the Shaker Heights Median Income of \$51,124.08, adjusted annually; and

WHEREAS, the proposed contract approved by City Council pursuant to Ordinance No. 97-160 has been modified accordingly to reflect the change relative to the loan fee, as described herein; and

WHEREAS, the proposed contract, as modified, is attached hereto and included herein by reference, and no other substantive modifications have been made to the contract approved pursuant to Ordinance No. 97-160.

NOW, THEREFORE, BE IT ORDAINED by the Council of the City of Shaker Heights, State of Ohio:

Section 1. Ordinance No. 97-160, enacted by City Council on September 22, 1997, and which authorized a contract with Fifth Third Bank relative to a home improvement and repair program, is hereby amended by substituting the contract attached hereto, and included herein by reference, with the contract attached to

Ordinance No. 97-160. In all other respects Ordinance No. 97-160 shall remain in full force and effect.

Section 2. This ordinance shall take effect from and after the earliest time allowed by law.

Enacted _____, 1997.

Approved this _____ day of _____, 1997.

PATRICIA S. MEARNS, Mayor

Attest:

WILLIAM J. SCHUCHART
Clerk of Council

coun97/t1b1105

ORDINANCE NO. 97-160
BY: Jan M. Devereaux

Authorizing a contract with Fifth Third Bank relative to a home improvement and repair program.

WHEREAS, pursuant to the City's Comprehensive Housing Affordability Plan, as amended by the Housing Advisory Board on August 25, 1994, and as approved by City Council pursuant to Ordinance No. 94-145, enacted on August 29, 1994, the City may provide for home improvement loans and programs, either directly or through contracts with lending institutions; and

WHEREAS, three separate loan programs have been approved by Council in accordance with the Housing Advisory Board Affordability Plan, pursuant to Ordinance Nos. 92-105, 94-15 and 94-146, respectively; and

WHEREAS, the parties mutually seek to enter into a contract in order to provide for a reduced loan interest rate to be subsidized by the City.

NOW, THEREFORE, BE IT ORDAINED by the Council of the City of Shaker Heights, State of Ohio:

Section 1. This Council hereby authorizes the Mayor and the Director of Finance to enter into a contract with Fifth Third Bank for the purpose of providing a reduced loan interest rate to be subsidized by the City, for home improvements and repairs. The contract shall be in substantially the form as attached hereto and included herein by reference, as approved by the Director of Law.

Section 2. This Council hereby authorizes the Mayor and Director of Finance to deposit ONE HUNDRED THOUSAND DOLLARS (\$100,000), in an interest-bearing account for a term of up to two (2) years with Fifth Third Bank as part of a program wherein the Bank will provide home improvement and repair loans as described herein.

Section 3. There is hereby appropriated from the General Capital Fund the sum of ONE HUNDRED THOUSAND DOLLARS (\$100,000), to be pledged as a compensating balance in furtherance of the provisions of this program.

Section 4. This ordinance shall take effect from and after the earliest time allowed by law.

Enacted September 22, 1997.

Approved this 23rd day of September, 1997.

PATRICIA S. MEARNS, Mayor

Attest:

WILLIAM J. SCHUCHART
Clerk of Council

MEMORANDUM

DATE: November 4, 1997
TO: Terrence Brennan, Chief Counsel
FROM: Jody Friedlander, Housing Preservation Administrator *JF*
RE: Fifth Third Agreement

NOV 4 1997

I am annexing four counterparts of the referenced agreement which have been signed by the bank. Please forward them for completion and execution in accordance with all appropriate City procedures.

Let me know if I can be of further assistance.

Thank you.

C: Phil Heintzelman, Director of Planning and Development
Frank Brichacek, Jr., Assistant Finance Director



AGREEMENT

BETWEEN THE CITY OF SHAKER HEIGHTS, OHIO, AND FIFTH THIRD BANK OF NORTHEASTERN OHIO FOR THE PROVISION OF HOME IMPROVEMENT AND REPAIRS LOANS.

This AGREEMENT, made at Shaker Heights, Ohio, as of the ____ day of _____, 1997, by and between the CITY OF SHAKER HEIGHTS, an Ohio municipal corporation, 3400 Lee Road, Shaker Heights, Ohio 44120, (216) 491-1400, (hereinafter designated the "CITY"), and FIFTH THIRD BANK OF NORTHEASTERN OHIO, (hereinafter designated the "BANK").

WITNESSETH:

For the mutual considerations herein described, the parties hereto agree as follows:

1. The CITY will deposit the sum of ONE HUNDRED THOUSAND DOLLARS (\$100,000) (the "Principal") in an interest-bearing account of the BANK, by no later than _____, 1997. Interest upon the Principal will accrue based upon the rate established for the Bank's Public Funds Sweep Account, adjusted quarterly. The CITY's Principal will remain deposited in the Public Sweeps Account at the BANK for period of two (2) years from the date of this AGREEMENT, subject to the terms and conditions of Paragraph 2 below.

2. The BANK agrees to apply the interest accrued upon said Principal, or portion thereof as necessary, to subsidize BANK loans for home improvements and repairs in Shaker Heights, so as to achieve a fixed loan rate of five percent (5%) for borrowers meeting the criteria established by the CITY and attached hereto as Exhibit A. It is understood and agreed that the BANK will transfer no more than fifty percent (50%) of the total amount of each loan closed from the Public Funds Sweep Account into a non-interest bearing subsidy account ("Subsidy Account") which will accrue interest at the Bank's Reinvestment Rate, adjusted quarterly. The Subsidy Account will be used by the BANK to compensate for the difference in interest between the 5% subsidized interest rate the borrower is to be charged by the BANK through the Shaker Heights Loan Program and the Home Improvement Market Rate (hereinafter defined) which is the actual interest rate the BANK will be charging and for which the Subsidy Account will be providing such compensation. The BANK will calculate how much subsidy will be required to offset the interest rate at the time the BANK closes the loan. The BANK will then transfer the sum needed into the Subsidy Account. In no event may the BANK require or transfer more than 50% of the loan amount. In the event the amount needed to subsidize the interest rate according to the BANK exceeds 50% of the loan amount, the BANK agrees to absorb the difference. At the start of each quarter, the BANK will recompute the required City subsidy which will be based on the average daily balance of the loans for the previous quarter and the BANK's current quarter Reinvestment Rate. It is understood and agreed that loan subsidy requirements will be computed based upon the month of maturity of a loan, not the day of maturity of a loan.

3. Neither this provision nor this contract shall be construed to constitute a promise or commitment by the CITY to guarantee repayment of any loans provided by the BANK pursuant to this contract, nor shall the CITY's Principal, or any portion thereof, be applied as a subsidy or guarantee of any such loan, except as provided in Paragraph 5 below.

4. The BANK will charge borrowers an interest rate based upon the Bank's current Home Improvement Market Rate, adjusted quarterly as of the first day of January, April and August of each year. This rate will be subsidized as described in paragraph 2 and illustrated in Exhibit B attached hereto and made a part hereof. No loan fee may be charged by the BANK on any loan, provided a borrower does not exceed 100% of the Shaker Heights Median Income, as shown on Exhibit C, subject to updating by The CITY annually. In the event a borrower's income exceeds the Shaker Heights Median Income listed on Exhibit C, as same is adjusted annually, the BANK may charge the borrower a fee not to exceed \$180.00 to defray the costs of appraisal, attorneys fees and title work. This fee may be financed as part of the loan. No service fee may be charged by the BANK to the CITY. The CITY will not be responsible for the processing of any loan, provided, however, it is understood and agreed that the CITY will be monitoring all work to be done by or on behalf of the borrower. The CITY will review the specifications and scope of work requested by the borrower. Both the BANK and the CITY will proceed with the loans in accordance with the procedures established in Exhibit A. The BANK will release no funds to the borrower unless and until the Department of Planning and Development advises the BANK in writing that the work was done satisfactorily. The proceeds of each loan shall be paid in the name of the borrower by the BANK. The BANK will require that all contractors must provide the property owner with lien release certificates that all materialmen, laborers, and subcontractors have been paid or have delivered releases of their rights to assert mechanic's liens upon the property before any funds are disbursed for work performed.

5. Within 30 days after each calendar quarter, the BANK will provide to the CITY comprehensive quarterly written reports containing information related to loan activity and loan payments by borrowers including, but not limited to, names, addresses, monthly amount of borrower's loan payments, compensating loss balance, type of work and status. Such reports shall be in a form as approved by the CITY. The BANK will provide to the CITY a monthly list of borrowers (approved and denied) and an explanation regarding denial. The BANK agrees to secure a release from each borrower so that it may provide such information to the CITY. This paragraph and its terms shall survive the termination of this Agreement until all loans are repaid. It is understood that in the event the BANK is not willing to loan funds because of poor credit history or other concerns, it shall inform the CITY, the CITY shall have the right to request to guarantee such loan. In the event the BANK agrees, the CITY shall deposit a maximum of 50% of the outstanding Principal of the loan into a separate account at the BANK as such guarantee. The BANK hereby agrees not to refuse any reasonable request by the CITY.

6. Delinquent loans may be subject to collection procedures instituted by the BANK in accordance with banking custom and applicable state and federal law, provided: (a) the CITY is given written notice of a delinquency; and (b) within ten (10) days after such notice, possible CITY intervention or other measures taken by or on behalf of the borrower have not remedied the default. The foregoing notwithstanding, the BANK may institute a foreclosure proceeding after ninety (90) days from the date the loan is past due, as the BANK deems appropriate. The BANK may, in its reasonable discretion, charge reasonable and customary collection fees on to borrower on delinquent loans. In the event a loan is guaranteed by the CITY, for loans with an outstanding Principal not to exceed \$2,000, a default for the purposes of this AGREEMENT only is defined as a total of three (3) full payments in arrears. Before the CITY will pay the guarantee, the BANK must seek and obtain a valid deficiency judgment from the court. The amount of the guarantee shall be 50% of the outstanding Principal balance, reduced by one-half of any funds recouped by the BANK. For loans with an outstanding Principal greater than \$2,000, the BANK must pursue full legal foreclosure before the CITY will pay the guarantee. In this event, the proceeds of any sale shall be applied first to interest, second to principal, and lastly to BANK costs.

7. The BANK agrees that the loans authorized pursuant to this contract will conform to all applicable state and federal laws, including but not limited to Fair Housing laws, and further, that it will not discriminate in the processing, issuance or administration of such loans on the basis of race, color, creed, national origin, ancestry, age, sex, familial status, or handicap.

8. This AGREEMENT is renewable only upon written agreement of the parties. Either party hereto shall have the right and option to cancel this AGREEMENT for any cause whatsoever upon the giving of at least ninety (90) days prior written notice of one party to the other. In the event of a cancellation, a) the BANK agrees to continue to service open loans until they are paid in full and b) the CITY shall have the right to remove any unobligated fund balance.

This AGREEMENT shall be deemed to contain all the terms and conditions agreed to between the parties, who both agree that no representations or promises of any kind whatsoever have been made other than herein contained, and this AGREEMENT shall be binding upon both parties and their respective heirs, administrators, executors, successors, and assigns.

IN WITNESS WHEREOF, the parties to this AGREEMENT have hereunto set their hands as of the day and year first above written.

Signed in the presence of:

**FIFTH THIRD BANK OF
NORTHEASTERN OHIO**

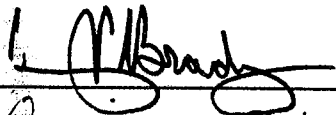
Kuana Jones

By Donald Shelton S.V.P.

And Louise J. Henderson A.V.P.

THE CITY OF SHAKER HEIGHTS

By _____
Mayor

And _____
Director of Finance

APPROVED AS TO FORM:

By _____
Director of Law

DRAFT 10/22/97

LIST OF EXHIBITS

Exhibit A	Term Definition, Criteria and Credit Guidelines
Exhibit B	Rate Subsidy Illustration
Exhibit C	Income Eligibility Chart

EXHIBIT A

TERM: Maximum fifteen (15) years

INTEREST: Shall be determined and calculated by the following:

- a) Loan Rate to Borrower: the Bank's Home Improvement Market Rate, adjusted to five (5%) percent annual percentage rate.
- b) City Principal: rate established for the Bank's Public Funds Sweep Account, adjusted quarterly.
- c) Subsidy Rate: rate established for the Bank's Reinvestment Rate, adjusted quarterly which will be credited to City for funds held in a non-interest bearing Subsidy Account used to offset the interest loss on the borrower's 5% rate.
- d) Unsubsidized Loan Rate to Borrower: rate established for the Bank's Home Improvement Market Rate, adjusted quarterly.

AMOUNT OF LOAN: UP TO \$30,000

CRITERIA:

The BANK shall provide home improvement loans to approved loan applicants in Shaker Heights whose income is at or below 100% of the Shaker Heights Median Income, subject to adjustment annually by the CITY. The BANK shall determine income eligibility for the borrower based on the following chart:

INCOME ELIGIBILITY

1 person household	\$ 38,500
2 person household	51,000
3 person household	74,000
4 person household	89,500
5 person household	98,500
6 person household	108,500
7 person household	120,000
8 person household	133,000

The BANK understands and agrees that the CITY must approve the scope and type of work to insure that such work is in keeping with the quality and type of work which the CITY is prepared to subsidize. To that end, the borrower must obtain two bids from registered City contractors (if the work to be performed requires such registration). Once the CITY has reviewed the specifications for the work, the CITY will forward to the BANK an authorization to proceed once the CITY has approved the scope of work. The CITY will monitor the work through procedures that the CITY establishes from time-to-time. The CITY shall have the right to modify the loan criteria stated in this Exhibit A from time-to-

in its discretion, provided the CITY gives the BANK thirty (30) days notice of such changes. The BANK will release funds only in accordance with Paragraph 4 of this AGREEMENT.

CREDIT GUIDELINES

The BANK will use special credit guidelines for this loan program which includes a debt ratio guide as follows:

Gross Annual Income	Gross Monthly Income	Ratio Guide
\$40,000 or less	\$3,333 or less	41%
\$40,001 and up	\$3,334 or more	44%

Non traditional references will be considered, i.e., payment of utilities, rent, etc. Applicant should have a clean credit history for the last 24 months. Bankruptcies must have been discharged for at least three years.

EXHIBIT B

Community Development Home Improvement Program

Loan 31,000
 Refinancing Rate 8.78%

Loan Term (Mos)	8 % Loans		
	Interest Loss	Comp. Bal. Term (Mos)	Comp. Bal. % Avg. Bal.
12	22.32	3.84	65%
24	43.21	7.84	64%
36	64.38	11.38	63%
48	85.84	15.17	63%
60	107.57	18.01	63%
72	129.57	22.80	64%
84	151.88	28.84	64%
96	174.42	30.88	64%
108	197.25	34.88	65%
120	220.37	38.95	65%
132	243.75	43.08	65%
144	267.41	47.28	65%
156	291.35	51.48	65%
168	315.55	55.77	65%
180	340.02	60.08	67%

	8 % Loans
6/2/97 Second Mortgage Rate	9.10%
Servicing %	0.00%
Market Rate	9.10%
Subsidized Rates	5.00%
Yield Rate Loss	4.10%

EXHIBIT C

As of the date of this Agreement, 100% of the 1990 Shaker Heights Median Income is \$51,124 ("Median Income"). Any resident exceeding this income may be charged a fee by the BANK of \$180 for appraisals, title and bank legal fees. It is understood and agreed that the CITY has the right to adjust the Median Income annually.

ORDINANCE NO. 97-185
BY: Allen D. Foster, Sr.

Confirming the granting of a conditional use permit for the installation of rooftop antennae at Tower East, 20600 Chagrin Boulevard (Ameritech).

BE IT ORDAINED by the Council of the City of Shaker Heights, State of Ohio:

Section 1. This Council hereby confirms the granting of a conditional use permit by the City Planning Commission at its meeting on November 3, 1997, for the installation of nine (9) panel rooftop antennae by Ameritech Wireless Communications, Inc. on the penthouse at Tower East, 20600 Chagrin Boulevard, Shaker Heights, Ohio.

Section 2. This ordinance shall take effect from and after the earliest time allowed by law.

Enacted November 24, 1997.

Approved this 25th day of November, 1997.

PATRICIA S. MEARNS, Mayor

Attest:

WILLIAM J. SCHUCHART
Clerk of Council

RESOLUTION NO. 97-186
BY: Kenneth J. Kovach

Providing for the continuation of cable operations under the current cable franchise agreement.

WHEREAS, in October, 1985 the City of Shaker Heights enacted Ordinance No. 85-96 which is the current franchise agreement between the City and Cablevision, Inc.; and

WHEREAS, the term of said franchise agreement was set to expire at the end of June 1995; and

WHEREAS, this Council agreed that cable operations would continue to be governed by the current franchise agreement (Ordinance No. 85-96); and

WHEREAS, the City entered into franchise negotiations with Cablevision, Inc. at the end of June 1995; and

WHEREAS, the City is continuing to negotiate a cable franchise with Cablevision, Inc. and has not yet reached agreement.

NOW, THEREFORE, BE IT RESOLVED by the Council of the City of Shaker Heights, State of Ohio:

Section 1. This Council hereby agrees that cable operations will continue to be governed by the current franchise agreement (Ordinance No. 85-96) until December 22, 1997.

Section 2. The Council is hereby instructed to furnish Cablevision, Inc. with a duly inscribed, attested and approved copy of this resolution.

Adopted November 24, 1997.

Approved this 25th day of November, 1997.

PATRICIA S. MEARNS, Mayor

Attest:

WILLIAM J. SCHUCHART
Clerk of Council

ORDINANCE NO. 97-187
BY: Jan M. Devereaux

Accepting certain construction, operation, and maintenance easements for the improvement of traffic signals in the City of Shaker Heights, and declaring an emergency.

WHEREAS, in order to improve the traffic signals in the City of Shaker Heights, it is necessary for the City to acquire certain easements for the construction, operation, and maintenance of certain traffic signal improvements.

NOW, THEREFORE, BE IT ORDAINED by the Council of the City of Shaker Heights, State of Ohio:

Section 1. The easements attached hereto as Exhibits 1, 2, 3, 4 and 5, and incorporated herein by reference, are hereby accepted by the City of Shaker Heights.

Section 2. The Mayor and such other officials of the City, as may be required, are hereby authorized to execute the easements approved herein, and related documents, as approved by the Director of Law.

Section 3. The easements authorized to be accepted herein shall be filed and recorded in the Cuyahoga County Auditor's Office, as directed by the Director of Law.

Section 4. This ordinance is hereby declared to be an emergency measure immediately necessary for the public peace, health, safety, and welfare for the reason that it is necessary to accept these easements in order to allow for continued improvements to traffic signals and, therefore, this ordinance shall take effect immediately upon its enactment and approval by the Mayor.

Enacted November 24, 1997.

Approved this 25th day of November, 1997.

PATRICIA S. MEARNs, Mayor

Attest:

WILLIAM J. SCHUCHART
Clerk of Council

**EASEMENT FOR THE CONSTRUCTION,
OPERATION AND MAINTENANCE OF
TRAFFIC SIGNAL DEVICES**

For and in consideration of One Dollar (\$1.00) the receipt of which is hereby acknowledged by the City of Shaker Heights hereinafter referred to as Grantor (whether one or more) do hereby grant and convey unto the City of Shaker Heights, its successor and assigns, hereinafter referred to as Grantee, a perpetual easement for the construction, maintenance, inspection, operation, protection, repair and replacement of Traffic Signal Equipment including buried conduit, controller, loop detector and all associated wiring and appurtenances within the following described lands of which the Grantor warrants he/she is the owner:

Situated in the City of Shaker Heights, County of Cuyahoga and State of Ohio and known as being part of the Van Sweringen Company's Subdivision No. 29 of part of Original Warrensville Township Lot No. 46 and being further located within the following described points in the boundary thereof:

Beginning at the intersection of the original centerline of Warrensville Center Road (110 feet wide) and the centerline of Farnsleigh Drive (60 feet wide);

Thence North $00^{\circ} 02' 45''$ West along the centerline of Warrensville Center Road a distance of 784.60 feet to a point;

Thence North $89^{\circ} 57' 15''$ East a distance of 30.00 feet to a point on the easterly right-of-way line of Warrensville Center Road and is the True Place of Beginning for the parcel herein described;

Thence along the proposed easement line by the following bearings and distances:

North $00^{\circ} 02' 45''$ West a distance of 50.00 feet along the easterly right-of-way of said Warrensville Center Road to a point;

Thence North $89^{\circ} 57' 15''$ East a distance of 15.00 feet to a point;

Thence South $00^{\circ} 02' 45''$ East a distance of 50.00 feet to a point;

Thence South $89^{\circ} 57' 15''$ West a distance of 15.00 feet to the True Place of Beginning and containing 750 square feet, be the same, more or less, but subject to all legal highways and easements of record.

The above described area is part of Permanent Parcel No. 736-11-21.

"Basis of Bearing"

Bearings taken from "Map of Survey, Thornton Park Property" performed by Adache-Cimi-Lynn Associates, March, 1988.

**EASEMENT FOR THE CONSTRUCTION,
OPERATION AND MAINTENANCE OF
TRAFFIC SIGNAL DEVICES**

For and in consideration of One Dollar (\$1.00) the receipt of which is hereby acknowledged by the City of Shaker Heights hereinafter referred to as the Grantor (whether one or more) do hereby grant, and convey unto the City of Shaker Heights, its successors and assigns, hereinafter referred to as the Grantee, a perpetual easement for the construction, maintenance, inspection, operation, protection, repair and replacement of Traffic Signal Equipment including: buried conduit, power service and associated wiring within the following described lands, of which the Grantor warrants he is the owner:

Situated in the City of Shaker Heights, County of Cuyahoga and State of Ohio and known as being part of the Original Warrensville Township Lot No. 35, and being further located within the following described points in the boundary thereof:

Beginning at the intersection of the centerline of Shaker Blvd (E.B.) (70 feet wide) and the centerline of Warrensville Center Road (110 feet wide);

Thence North $00^{\circ} 07' 45''$ West along the centerline of Warrensville Center Road a distance of 63.00 feet to a point;

Thence South $89^{\circ} 52' 15''$ West a distance of 55.00 feet to a point on the westerly right-of-way line of Warrensville Center Road and the True Place of Beginning for the parcel herein described;

Thence along the proposed easement line by the following bearings and distances:

Southwesterly along the existing right-of-way an arc distance of 43.98 feet (radius = 28.00 feet, chord = 39.60 feet, chord bearing South $44^{\circ} 52' 15''$ West) to a point;

North $00^{\circ} 07' 45''$ West a distance of 28.00 feet to a point on the existing northerly right-of-way line of Shaker Blvd. (EB);

Thence North $89^{\circ} 52' 15''$ East a distance of 28.00 feet to the True Place of Beginning and containing 615.85 square feet of land, be the same, more or less, but subject to all legal highways and easements of record.

The above described area is part of Permanent Parcel No. 733-23-20.

"Basis of Bearing"

Bearings are taken from the Resubdivision of the Van Swerigen Co. Subdivision No. 15, Volume 87, Page 39.

Together with the right of unimpaird access to said Traffic Signal Equipment and the right of ingress and egress on, over, and through the above described land for any and all purposes necessary and incident to the exercise by said Grantee of the rights granted hereunder.

The said Grantor shall have the right to use and enjoy the above described land except as the same may be necessary for the purposes herein granted to the said Grantee. Grantor agrees not to build, create, or construct any obstructions, engineering works, or other structures over said Traffic Signal Equipment nor permit the same to be done by others. If Grantee has to excavate this area in order to repair or replace said Traffic Signal Equipment, they agree to restore the property to its original condition.

The rights herein granted may be assigned in whole or in part.

The terms, conditions, and provisions of this Right-of-Way Easement shall extend to and be binding upon the heirs, executors, administrators, personal representatives, successors and assigns of the parties hereto.

IN WITNESS WHEREOF, the Grantor herein has hereunto set his hand this _____ day of _____ of 19__.

Signed and sealed in the presence of:

STATE OF OHIO)
) ss
COUNTY OF CUYAHOGA)

Before me, the undersigned, a Notary Public in and for said County and State on this _____ day of _____, 19__, personally appeared _____ to me known to be the identical person who executed the within and foregoing instrument by this mark in my presence and in the presence of _____.

AS WITNESSES, and acknowledged to me that he executed the same as his free, voluntary act and deed for the uses and purposes therein set forth.

Given under my hand and seal the day and year last above written.

NOTARY PUBLIC
My commission expires

(SEAL)

Approved and accepted this _____ day of _____, 19__.

BY: _____

N

SCALE: 1"=40'

PPN 733-23-20

TRAFFIC SIGNAL EASEMENT
615.8 S.F.

28.00'
N 89° 52' 15" E

28.00'
N 0° 07' 45" W

55.00'

N 0° 07' 45" W

55.00'

63.00'

SHAKER BLVD (E.B.)

FALMOUTH RD.

142.57'
N 89° 52' 15" E

83.00'

WARRENSVILLE CTR. RD. (110')

CURVE DATA

R = 28.00'

T = 28.00'

Δ = 90° 00' 00"

A = 43.98'

C = 39.60'

S 44° 52' 15" W

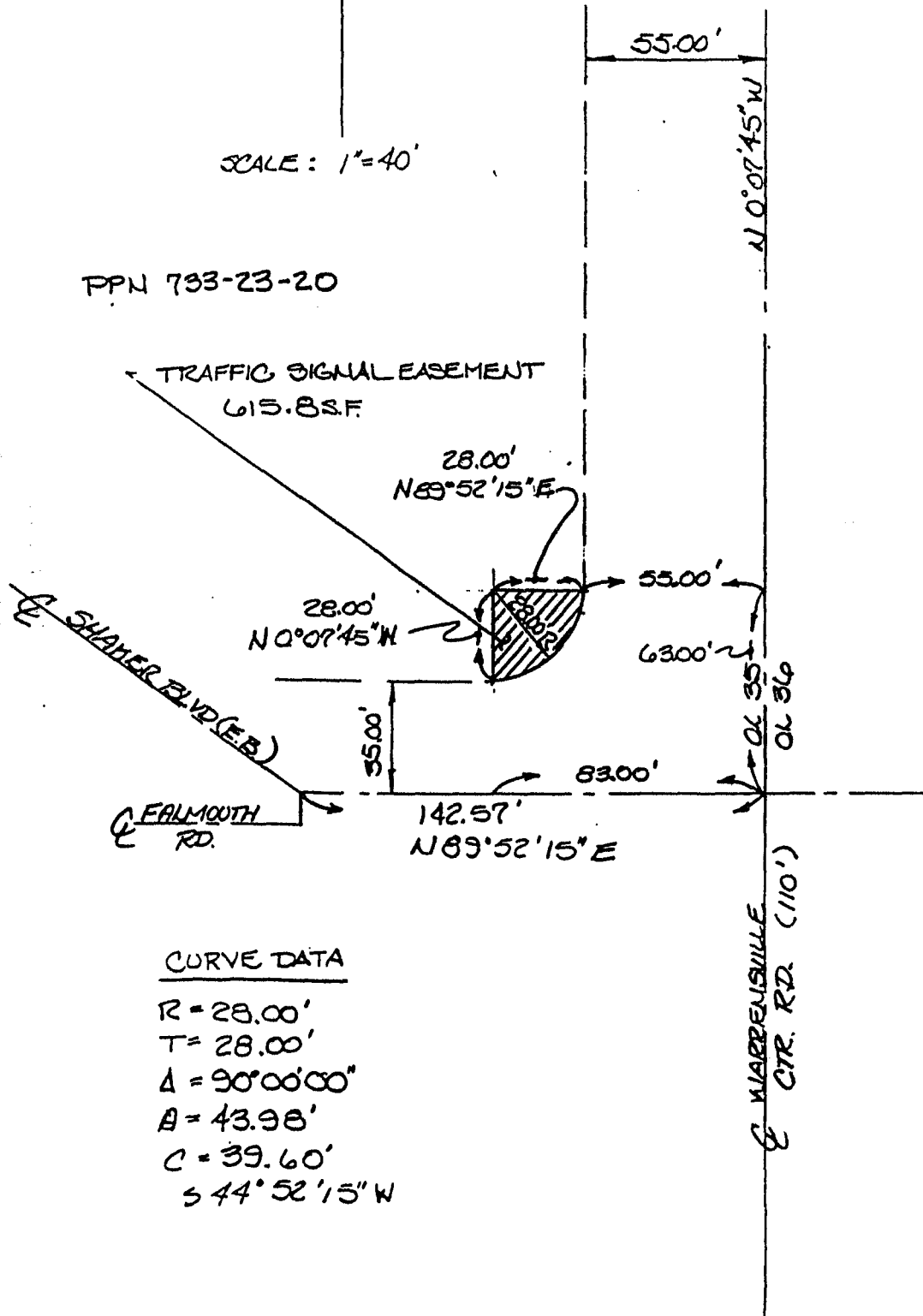

**EASEMENT FOR THE CONSTRUCTION,
OPERATION AND MAINTENANCE OF
TRAFFIC SIGNAL DEVICES**

For and in consideration of One Dollar (\$1.00) the receipt of which is hereby acknowledged by the City of Shaker Heights, hereinafter referred to as the Grantor (whether one or more) do hereby grant, and convey unto the City of Shaker Heights, its successors and assigns, hereinafter referred to as the Grantee, a perpetual easement for the construction, maintenance, inspection, operation, protection, repair and replacement of a Traffic Signal Loop Detector Device within the following described lands of which Grantor warrants he is the owner:

Situated on the City of Shaker Heights, County of Cuyahoga, State of Ohio, and known as being a part of the Original Warrensville Township Lot No. 42, and being further located within the following described points in the boundary thereof:

Beginning at an iron pipe monument at the centerline intersection of Chagrin Blvd. (width varies) and Lee Roads (width varies). Thence along the west centerline of Lee Road along the curve to the right with a radius of 4,844.18 feet (Arc= 305.57 feet, chord= 305.52 feet, chord bearing North 03° 06' 24" West);

Thence South 89° 20' 09" West a distance of 43.00 feet to the True Place of Beginning for the parcel herein described;

Thence along the proposed easement line by the following bearings and distances:

Along a curve to the left with a radius of 4887.18 feet (arc = 40.00 feet, chord = 40.00 feet and chord bearing South 01° 31' 42" East) to a point;

South 89° 20' 09" West a distance of 41.00 feet to a point;

North 01° 31' 42" West a distance of 40.00 feet to a point;

Thence North 89° 20' 09" East a distance of 41.00' to the True Place of Beginning and containing 1,639.2 square feet of land, be the same, more or less, but subject to all legal highways and easements of record.

The above described area is a part of Permanent Parcel No. 735-16-22.

"Basis of Bearing"

Bearings taken from the Subdivision Plat of Board of Education Property City of Shaker Heights, Volume 243, Page 94.

Together with the right of unimpaired access to said Traffic Signal Loop Detector Device and the right of ingress and egress on, over, and through the above described land for any and all purposes necessary and incident to the exercise by said Grantee of the rights granted hereunder.

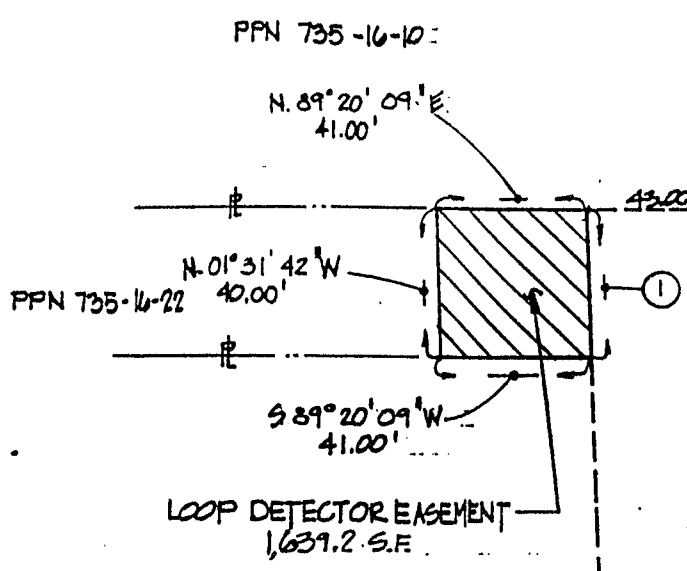

CURVE DATA

① R = 4857.18'	② R = 4844.18'
Δ = 0° 28' 08"	Δ = 3° 36' 51"
A = 40.00'	A = 305.57'
C = 40.00'	C = 305.52'
S 1° 31' 42" E	N. 3° 06' 24" W

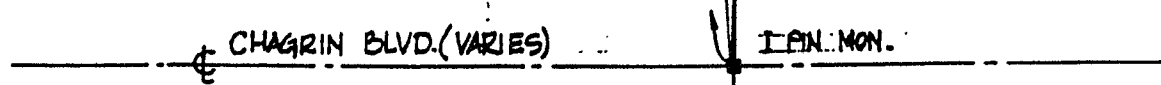
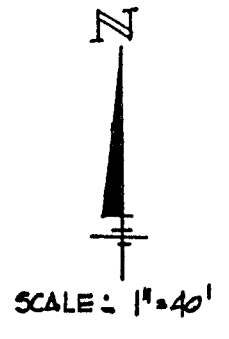
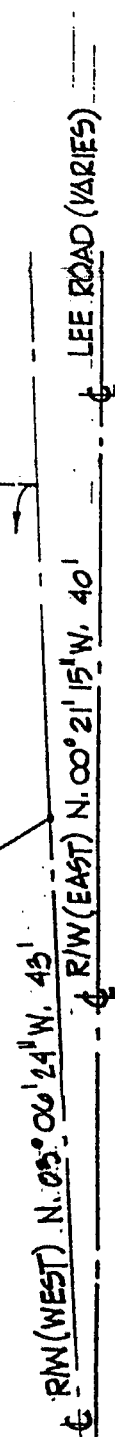

**EASEMENT FOR THE CONSTRUCTION,
OPERATION AND MAINTENANCE OF
TRAFFIC SIGNAL DEVICES**

For and in consideration of One Dollar (\$1.00) the receipt of which is hereby acknowledged by the City of Shaker Heights hereinafter referred to as Grantor (whether one or more) do hereby grant and convey unto the City of Shaker Heights, its successors and assigns, hereinafter referred to as Grantee, a perpetual easement for the construction, maintenance, inspection, operation, protection, repair and replacement of Traffic Signal Equipment including: controller, pullboxes, signal supports, vehicular and pedestrian signal heads, buried conduit, power service, associated wiring and other appurtenances, within the following described lands, of which the Grantor warrants he/she is the owner:

Situated in the City of Shaker Heights, County of Cuyahoga and State of Ohio and known as being part of the Van Swerigen Company's Subdivision No. 16 of part of the Original Warrensville Township Lots No. 31, 32, 41, 42, and 43 and being further located with the following described points in the boundary thereof:

Beginning at the intersection of the centerline of Lee Road (80 feet wide) and the centerline of Van Aken Blvd, formerly know as South Moreland Blvd (170 feet wide);

Thence North 00° 21' 15" West along the centerline of Lee Road a distance of 471.88 feet to a point;

Thence South 89° 38' 45" West a distance of 40.00 feet to a point on the westerly right-of-way of Lee Road and is the True Place of Beginning for the parcel herein described;

Thence along the proposed easement line by the following bearings and distances:

South 89° 38' 45" West a distance of 20.00 feet to a point;

North 00° 21' 15" West a distance of 30.00 feet to a point;

North 45° 21' 15" West a distance of 14.14 feet to a point;

South 89° 38' 45" West a distance of 10.00 feet to a point;

North 00° 21' 15" West a distance of 30.00 feet to a point;

North 89° 38' 45" East a distance of 20.00 feet to a point;

North 00° 21' 15" West a distance of 40.00 feet to a point;

North 89° 38' 45" East a distance of 20.00 feet to a point;

Thence South 00° 21' 15" East a distance of 110.00 feet along the westerly right-of-way line of said Lee Road to the True Place of Beginning and containing 2,850.00 square feet (0.065 acres) of land, be the same, more or less, but subject to all legal highways and easements of record.

The above described area is part of Permanent Parcel Numbers 735-4-20 and 735-4-21.

"Basis of Bearing"

Bearings taken from Plat for Van Swerigen Company's Subdivision No. 16, Volume 50, Page 24.

Together with the right of unimpaired access to said Traffic Signal Equipment and the right of ingress and egress on, over, and through the above described land for any and all purposes necessary and incident to the exercise by said Grantee of the rights granted hereunder.

The said Grantor shall have the right to use and enjoy the above described land except as the same may be necessary for the purposes herein granted to the said Grantee. Grantor agrees not to build, create, or construct any obstructions, engineering works, or other structures over said Traffic Signal Equipment nor permit the same to be done by others. If Grantee has to excavate this area in order to repair or replace said Traffic Signal Equipment, they agree to restore the property to its original condition.

The rights herein granted may be assigned in whole or in part.

The terms, conditions, and provisions of this Right-of-Way Easement shall extend to and be binding upon the heirs, executors, administrators, personal representatives, successors and assigns of the parties hereto.

IN WITNESS WHEREOF, the Grantor herein has hereunto set his hand this _____ day of _____ of 19____.

Signed and sealed in the presence of:

STATE OF OHIO)
) ss
COUNTY OF CUYAHOGA)

Before me, the undersigned, a Notary Public in and for said County and State on this _____ day of _____, 19____, personally appeared _____ to me known to be the identical person who executed the within and foregoing instrument by this mark in my presence and in the presence of _____.

AS WITNESSES, and acknowledged to me that he executed the same as his free, voluntary act and deed for the uses and purposes therein set forth.

Given under my hand and seal the day and year last above written.

NOTARY PUBLIC
My commission expires

(SEAL)

Approved and accepted this _____ day of _____, 19____.

BY: _____

TRAFFIC SIGNAL EASEMENT
2,850.00 SF (0.065 ACRES)

PP. # 735-4-21

PP. # 735-4-20

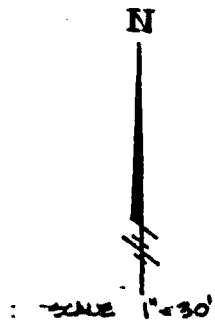

- | | |
|-------------------------------|-------------------------------|
| (A) 20.00'
S 89° 30' 45" W | (E) 30.00'
N 00° 21' 15" W |
| (B) 30.00'
N 00° 21' 15" W | (F) 20.00'
N 89° 30' 45" E |
| (C) 14.14'
N 45° 21' 15" W | (G) 40.00'
N 00° 21' 15" W |
| (D) 10.00'
S 89° 30' 45" W | (H) 20.00'
N 89° 30' 45" E |

VAN DYEN BLVD.

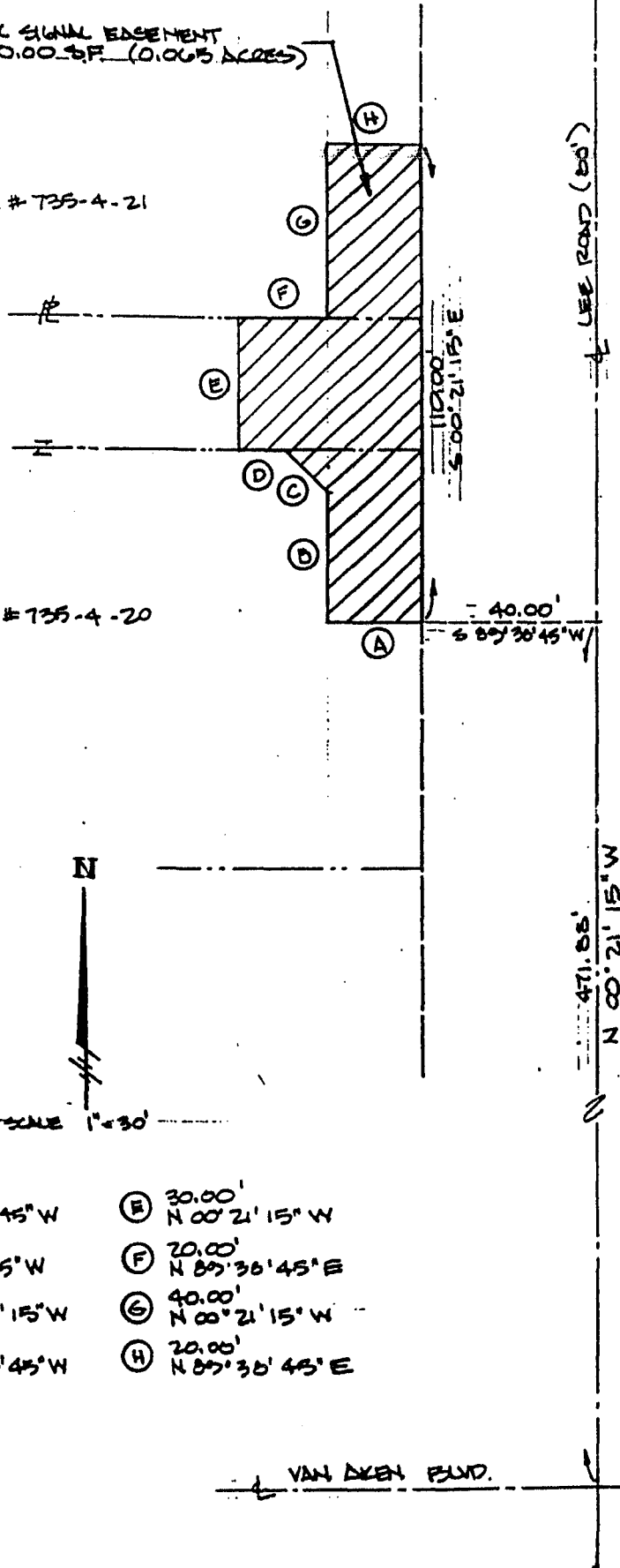

**EASEMENT FOR THE CONSTRUCTION,
OPERATION AND MAINTENANCE OF
TRAFFIC SIGNAL DEVICES**

For and in consideration of One Dollar (\$1.00) the receipt of which is hereby acknowledged by the City of Shaker Heights hereinafter referred to as Grantor (whether one or more) do hereby grant and convey unto the City of Shaker Heights, its successors and assigns, hereinafter referred to as Grantee, a perpetual easement for the construction, maintenance, inspection, operation, protection, repair and replacement of Traffic Signal Equipment including: controller, pullboxes, buried conduit, power service and associated wiring, within the following described lands, of which the Grantor warrants he/she is the owner:

Situated in the City of Shaker Heights, County of Cuyahoga and State of Ohio and know as being part of the Original Warrensville Township Lots No. 20 and No. 38, and being further located within the following described points in the boundary thereof:

Beginning at the intersection of the centerline of Green Road (86 feet wide) and the centerline of Shaker Blvd North Roadway (60 feet wide);

Thence South $00^{\circ} 01' 10''$ West along the centerline of Green Road a distance of 38.25 feet to an iron pin monument, said point being the northwest corner of the Original Warrensville Township Lot No. 38;

Thence North $89^{\circ} 59' 10''$ East a distance of 43.00 feet to a point on the existing easterly right-of-way line of Green Road and is the True Place of Beginning for the parcel herein described;

Thence along the proposed easement line by the following bearings and distances:

North $00^{\circ} 01' 10''$ East a distance of 8.38 feet to a point on the existing easterly right-of-way line and its intersection with the exiting southerly right-of-way line of Shaker Blvd North Roadway (60 feet wide);

Thence North $89^{\circ} 48' 50''$ East a distance of 100.00 feet along the southerly right-of-way line of Shaker Blvd North Roadway to a point;

Thence South $00^{\circ} 11' 10''$ East a distance of 10.00 feet to a point;

Thence South $89^{\circ} 48' 50''$ West a distance of 90.03 feet to a point;

Thence South $00^{\circ} 02' 50''$ East a distance of 14.90 feet to a point;

Thence South $89^{\circ} 57' 10''$ West a distance of 10.00 feet to a point on the easterly right-of-way line of Green Road;

Thence North $00^{\circ} 02' 50''$ West, along said easterly right-of-way line of Green Road a distance of 16.50 feet to the True Place of Beginning and containing 1,149.09 square feet (0.026 acres), be the same, more or less, but subject to all legal highways and easements of record.

The above described area is part of Permanent Parcel No. 734-36-1.

"Basis of Bearing"

Bearings taken from "Dedication Plat of Shaker Boulevard," Volume 117, Page 14.

Together with the right of unimpaired access to said Traffic Signal Equipment and the right of ingress and egress on, over, and through the above described land for any and all purposes necessary and incident to the exercise by said Grantee of the rights granted hereunder.

The said Grantor shall have the right to use and enjoy the above described land except as the same may be necessary for the purposes herein granted to the said Grantee. Grantor agrees not to build, create, or construct any obstructions, engineering works, or other structures over said Traffic Signal Equipment nor permit the same to be done by others. If Grantee has to excavate this area in order to repair or replace said Traffic Signal Equipment, they agree to restore the property to its original condition.

The rights herein granted may be assigned in whole or in part.

The terms, conditions, and provisions of this Right-of-Way Easement shall extend to and be binding upon the heirs, executors, administrators, personal representatives, successors and assigns of the parties hereto.

IN WITNESS WHEREOF, the Grantor herein has hereunto set his hand this _____ day of _____ of 19__.

Signed and sealed in the presence of:

STATE OF OHIO)
) ss
COUNTY OF CUYAHOGA)

Before me, the undersigned, a Notary Public in and for said County and State on this _____ day of _____, 19__, personally appeared _____ to me known to be the identical person who executed the within and foregoing instrument by this mark in my presence and in the presence of _____.

AS WITNESSES, and acknowledged to me that he executed the same as his free, voluntary act and deed for the uses and purposes therein set forth.

Given under my hand and seal the day and year last above written.

NOTARY PUBLIC
My commission expires

(SEAL)

Approved and accepted this _____ day of _____, 19__.

BY: _____

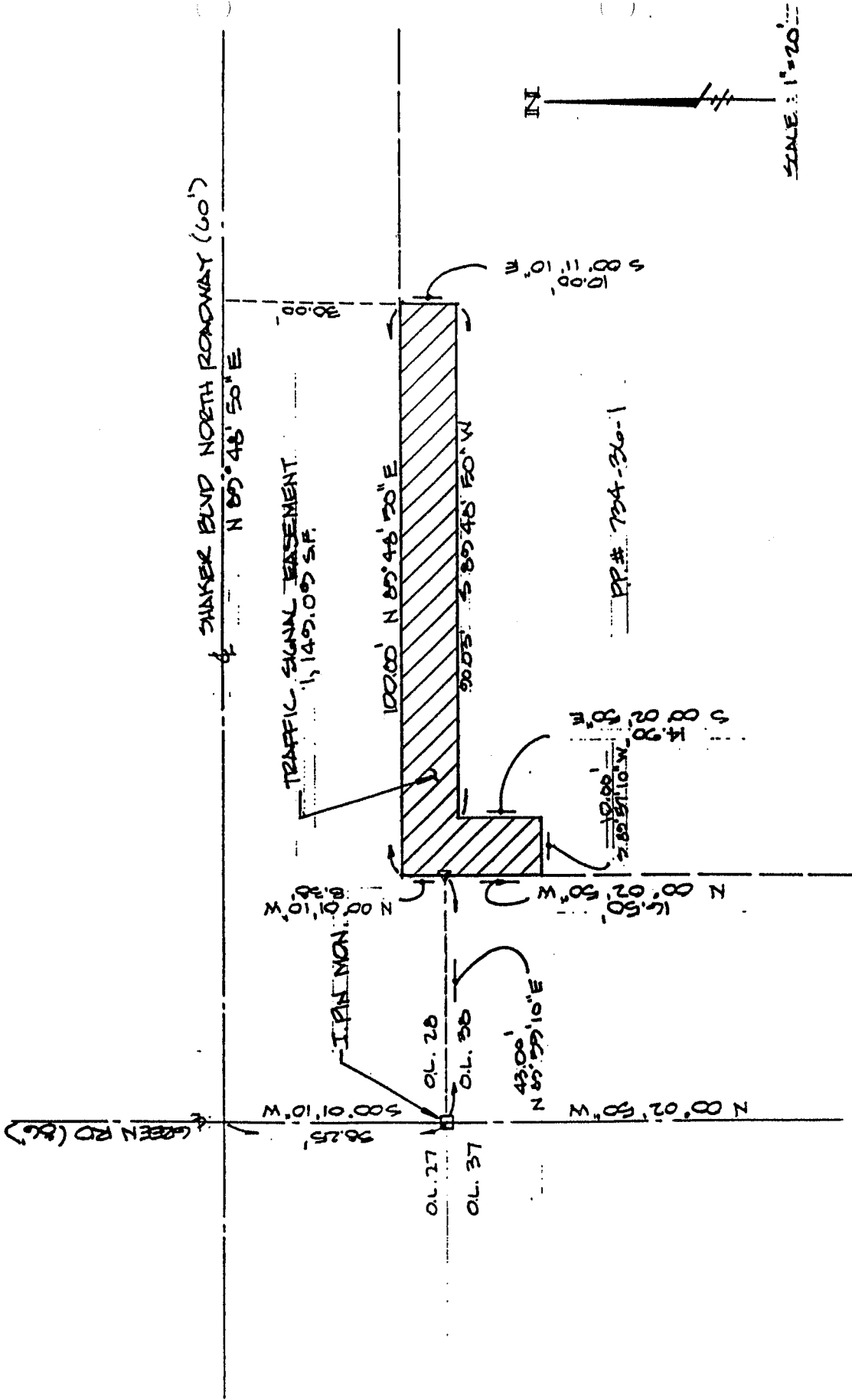

SHAKER BLVD NORTH ROWWAY (60')
 N 89°48'50"E

TRAFFIC SIGNAL BASEMENT
 1,149.09 SF.

100'00' N 89°48'30" E

50'00' S 89°48'50" W

TRAFFIC MON.

OL. 27

OL. 28

OL. 30

43'00' N 89°39'10" E

10'00' S 89°48'50" W

10'00' S 89°48'50" W

10'00' S 89°48'50" W

PP.# 734-36-1



SCALE: 1"=20'

GREEN RD (66')

500'01'10" W

N 00°02'50" W

N 00°01'10" W

N 00°02'50" W

38.25'

OL. 27

OL. 28

OL. 30

43'00' N 89°39'10" E

10'00' S 89°48'50" W

10'00' S 89°48'50" W

10'00' S 89°48'50" W

PP.# 734-36-1



SCALE: 1"=20'

GREEN RD (66')

500'01'10" W

N 00°02'50" W

N 00°01'10" W

N 00°02'50" W

38.25'

OL. 27

OL. 28

OL. 30

43'00' N 89°39'10" E

10'00' S 89°48'50" W

10'00' S 89°48'50" W

10'00' S 89°48'50" W

PP.# 734-36-1



SCALE: 1"=20'

